

SERVICE MANUAL

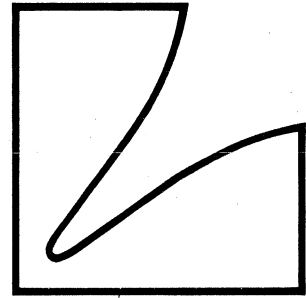

Stereo Cassette Deck

K-110W



Contents

Specifications	2
Parts Locations and Disassembly Instructions	3 to 6
Block Diagram	7
Adjustment Locations	8
Adjustment Procedures	9 to 12
Parts Layout on P. C. Boards and Wiring Diagram	13 to 15
Schematic Diagram (1/2)	16 to 19
Schematic Diagram (2/2)	20 to 23
Electrical Parts List	24 to 31
Parts List by the Destination	32
Cabinet Assembly Parts List	33
Exploded View (Cabinet)	34 to 35
Exploded View (Cassette Deck)	36 to 37
Cassette Deck Assembly Parts List	38 to 39
Packing Assembly Parts List	40
Packing Method View	40
Semiconductor Lead Identifications	41 to 44

Specifications

Power Source	AC 120V, 60Hz (UC, UQ model only) AC120V/220/240V, 50/60Hz (AD model only)
Tape Speed (MTT-111)	4.75cm/sec. +3%, -2%
Wow & Flutter (MTT-111, JIS WRMS)	≤0.11%
FF/REW Time (C-60)	≤105 sec.
Frequency Response (Playback, ±4dB)	Normal : 40Hz~14kHz CrO ₂ : 40Hz~16kHz Metal : 40Hz~16kHz
S/N Ratio (Over all JIS weighted "A" curve)	Dolby NR-OFF : Normal ≥50dB, CrO ₂ /Metal ≥52dB Dolby NR-B : Normal/CrO ₂ /Metal ≥57dB Dolby NR-C : Normal/CrO ₂ ≥63dB, Metal ≥65dB
Input Sensitivity	Line ≤100mV
Output Level at 0dB playback	Line : 500mV ±1.5dB/47k ohm Headphone ≤100mV/8 ohm
Distortion 3rd (0dBm input at 333Hz)	Normal : ≤2.5% CrO ₂ /Metal : ≤3%
Semiconductors	22 IC's, 82 Transistors, 39 Diodes, 4 Zener Diodes, 25 LED's
Chassis Dimensions	438 (W) ×100 (H) ×250 (D) mm
Weight	4.8kg

NOTE : Due to continuing product improvement, specifications and designs are subject to change without notice.

SERVICE MANUAL

Stereo Cassette Deck

Addendum K-110W

The following parts are added on the foil side of the main P.C. Board of K-110W: C118, C124, C275-278, C165/166, R449-454, R567/568. The layout of these parts are shown below.

Main P.C. Board

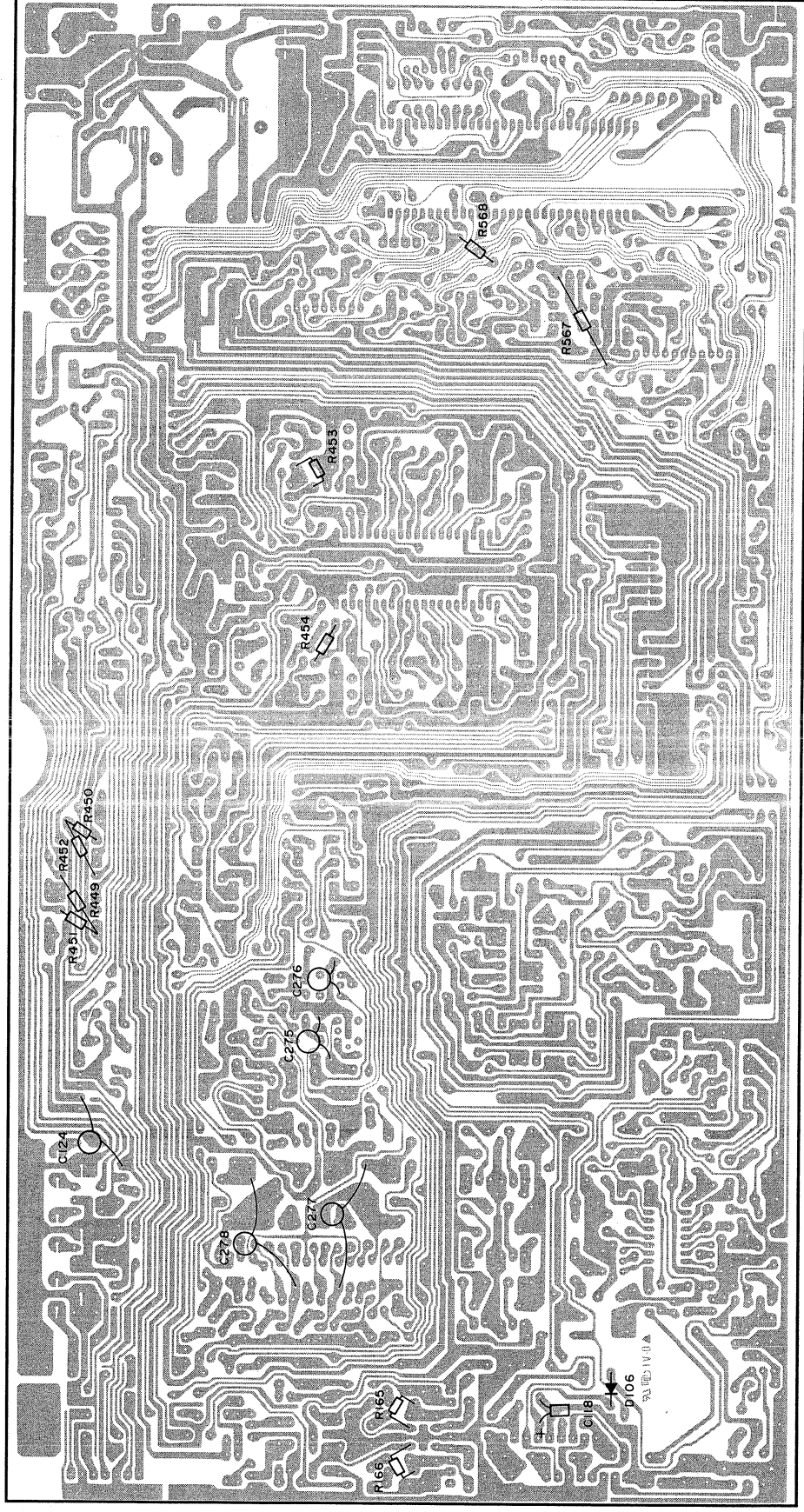

↑
D106 is added instead of R122 on the component side.

Parts Locations and Disassembly Instructions

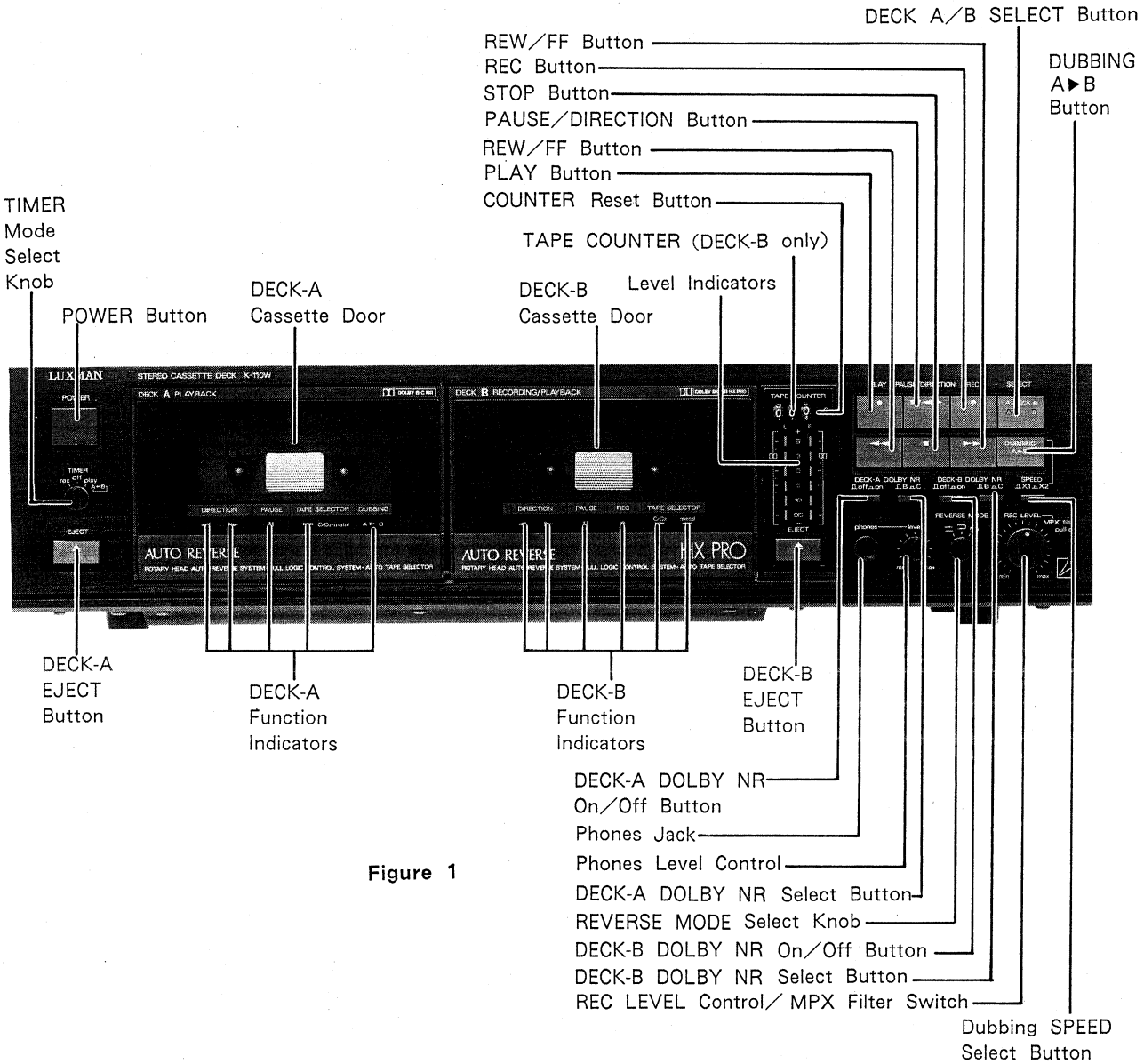

Figure 1

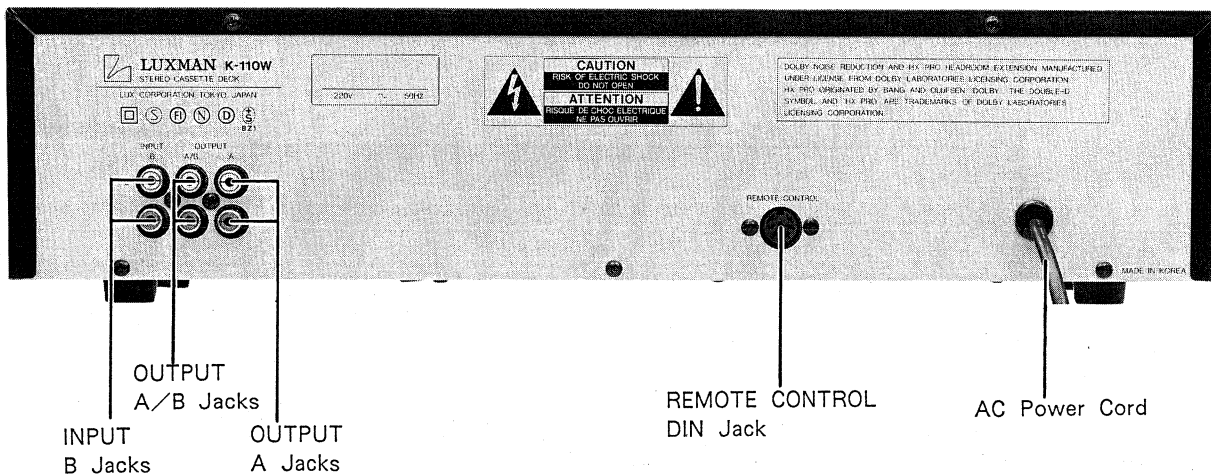

Figure 2

1. Removal of Top Cabinet (Figure 3)

- (1) Remove four screws marked (A) and four screws marked (I).
- (2) Slide off the top cabinet by pulling the both sides' bottoms slightly outside.

2. Removal of Front Panel (Figure 4)

- (1) Remove the top cabinet as shown above.
- (2) Disconnect all connectors from the main P. C. Board and both cassette decks.
- (3) Turn the unit upside down, and remove four screws marked (B) and three nylon rivets marked (H) from the bottom cabinet.
- (4) Remove the front panel by pulling it.

3. Removal of Cassette Deck Mechanisms (A and B) (Figure 5)

- (1) Remove the front panel as shown above.
- (2) Open the cassette doors by pressing the EJECT buttons.
- (3) To remove the cassette deck mechanism B, remove the belt from the counter pulley on the mechanism. (Be carefull not to miss the belt.) Skip this step for cassette deck A.
- (4) Remove four black screws (B) from each cassette deck mechanism.
- (5) Remove the cassette deck mechanisms from the front panel.
Be careful not to miss the slider with spacer and screw (shown by * in Figure 5) when removing the mechanism.

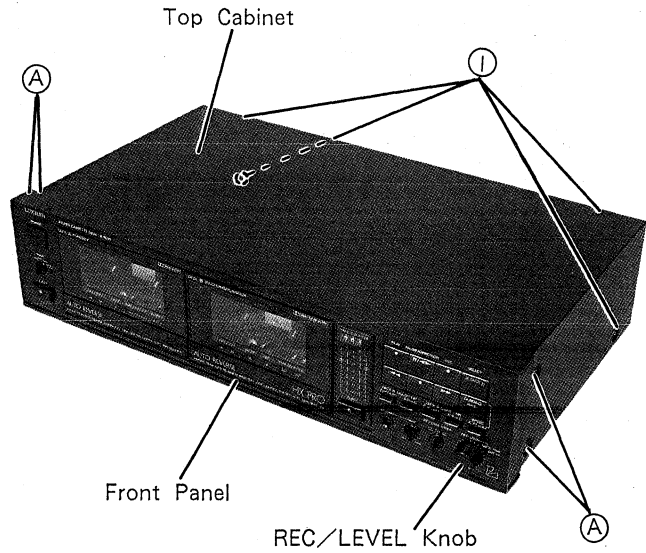

Figure 3

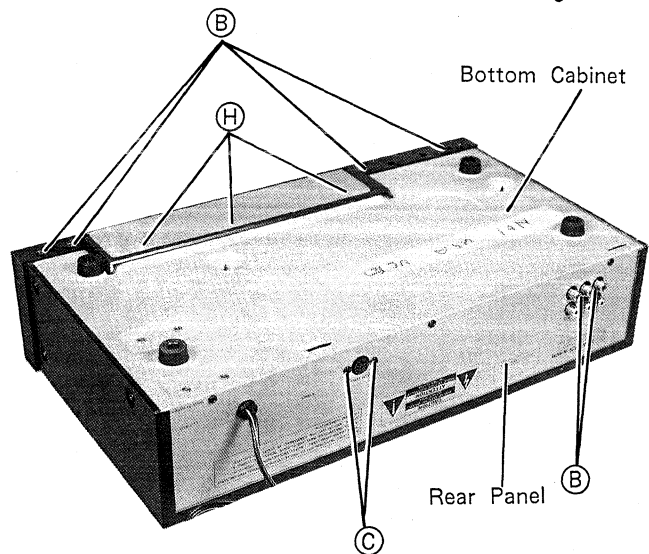

Figure 4

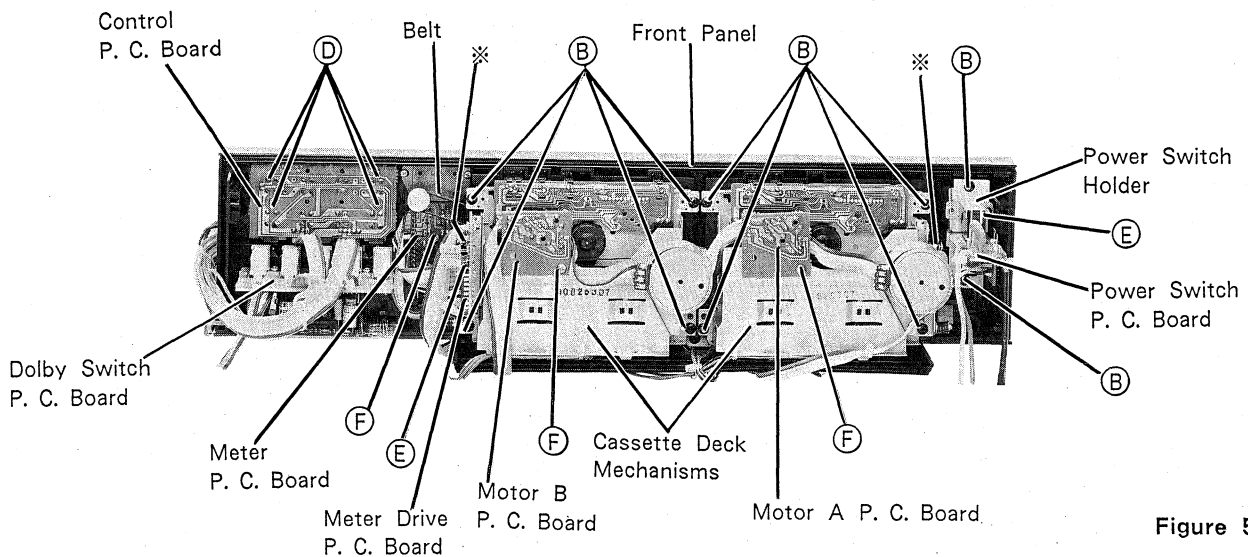

Figure 5

4. Removal of Main P. C. Board

(Figures 4 and 6)

- (1) Remove the top cabinet.
- (2) Disconnect all connectors from the main P. C. Board and the cassette decks.
- (3) Remove two screws (B) from the RCA jack section and two plastic rivets (C) from the remote control section on the rear panel. (Figure 4)
- (4) Remove four screws (B) from the P. C. Board. (Figure 6)

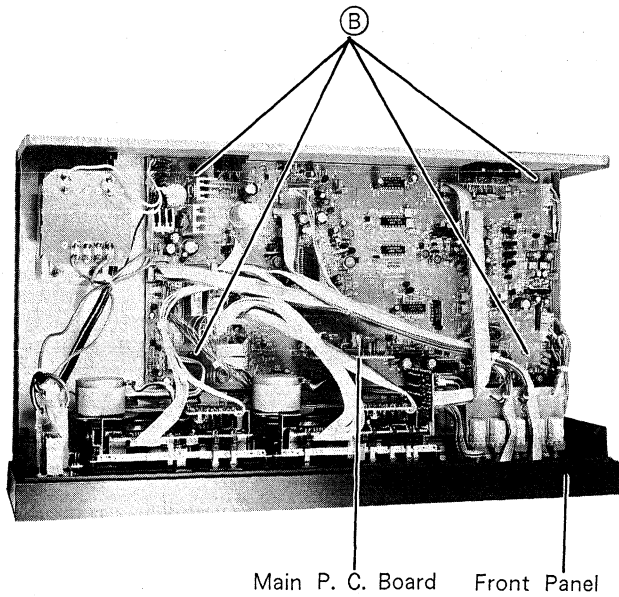

Figure 6

5. Removal of Control P. C. Board (Figure 5)

- (1) Remove the top cabinet.
- (2) Remove four screws (D) from the P. C. Board.

6. Removal of Power Switch P. C. Board

(Figure 5)

- (1) Remove the top cabinet.
- (2) Make sure that the power switch is off (not depressed.)
- (3) Remove two screws (B) that secure the power switch holder.
- (4) Pull the power switch P. C. Board with the holder strongly backward to remove the power switch shaft from the power switch knob.
- (5) Remove one screw (E) from the holder.

7. Removal of Dolby Switch P. C. Board

(Figure 7)

- (1) Remove the top cabinet.
- (2) Remove four screws (E) from the P. C. Board.

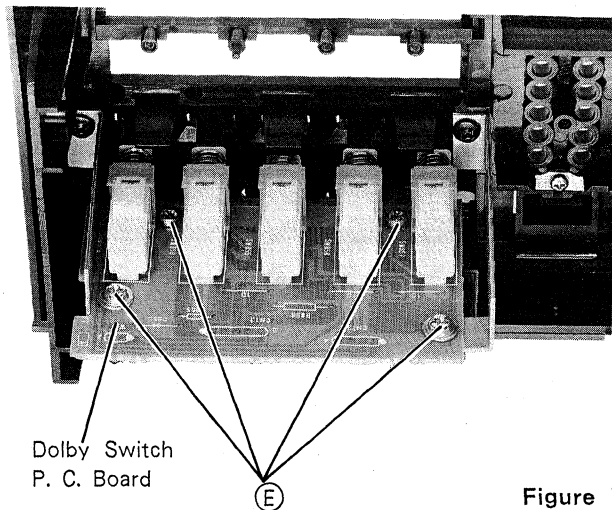

Figure 7

8. Removal of Headphone P. C. Board

(Figures 3 and 8)

- (1) Remove the top cabinet.
- (2) Remove the front panel.
- (3) Remove REC/LEVEL knob from the front panel by pulling it. (Figure 3)
- (4) You will find a nut with a washer in the hole after removing the REC/LEVEL knob. Remove the nut and washer.
- (5) Remove one screw (B) from the headphone holder. (Figure 8)

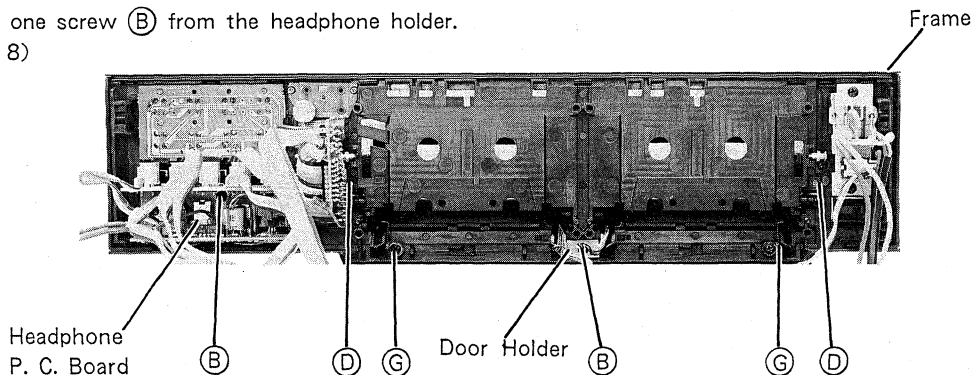

Figure 8

9. Removal of Meter P. C. Board (Figure 5)

- (1) Remove the top cabinet.
- (2) Remove one screw (F).

10. Removal of Meter Drive P. C. Board

(Figure 5)

- (1) Remove the top cabinet.
- (2) Remove one screw (E).

11. Removal of Motor P. C. Boards (A and B)

(Figure 5)

- (1) Remove the top cabinet.
- (2) To remove the motor P. C. Board of the cassette deck B, remove the front panel or the main P. C. Board.
For cassette deck A, skip this step.
- (3) Remove one screw (F) from each motor P. C. Board.

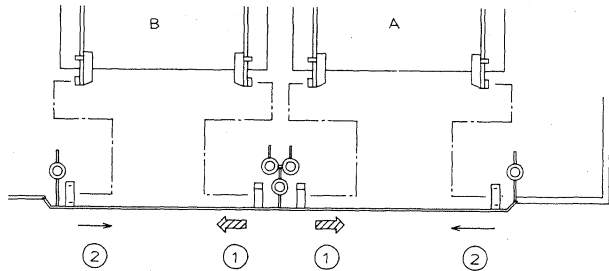

Figure 9

12. Removal of LED P. C. Boards

(Figures 8, 9 and 10)

- (1) Remove the front panel as shown in item 2.
- (2) Remove each cassette deck mechanism by removing four screws each as shown in Removal of Cassette Deck Mechanism.
- (3) Remove one screw (B) from the door holder. (Figure 8)
- (4) Remove two screws (C) that secure springs and washers to the frame. (Figure 8)
- (5) Remove two screws (D) that secure the damper assemblies and washers to the frame. (Figure 8)
- (6) Remove each cassette door by sliding off from the frame in the order shown in Figure 9.
- (7) Remove four screws (G) each from each cover. (Figure 10)
- (8) Each LED P. C. Board is secured by two detents (Figure 10) Remove the P. C. Boards from the detents.

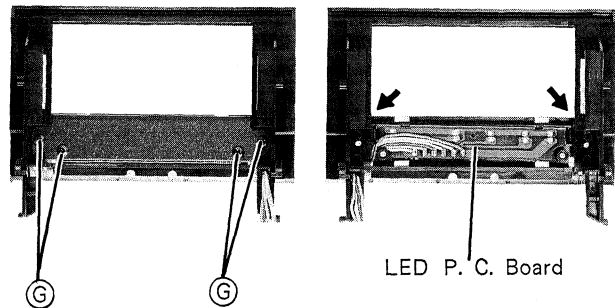
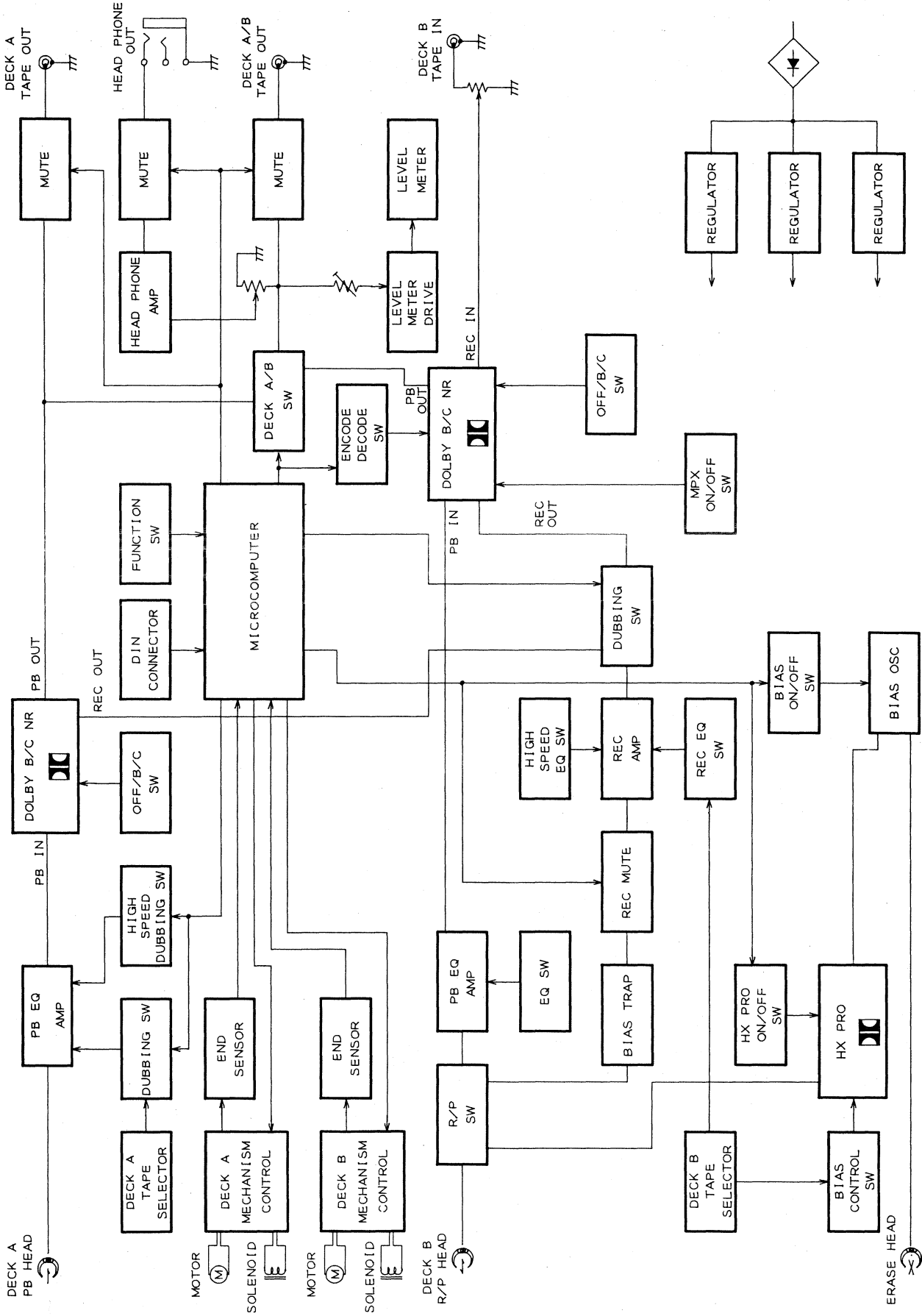
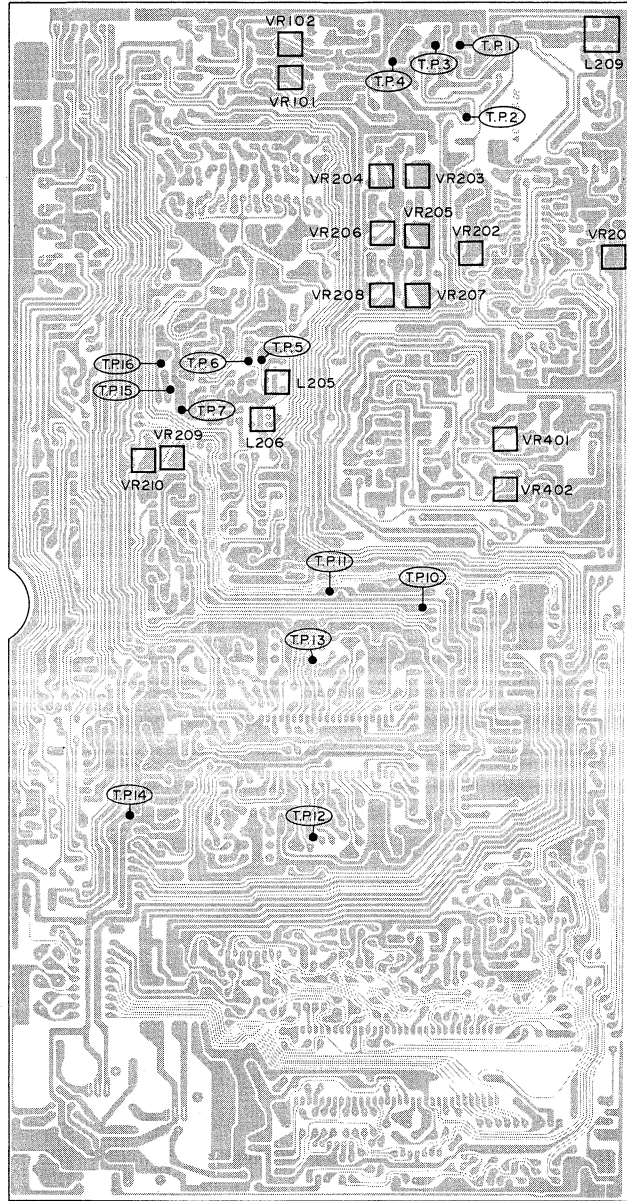

Figure 10

Block Diagram



Adjustment Locations



Main P. C. Board

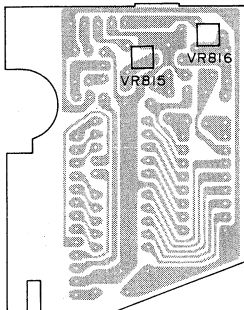

Meter Drive P. C. Board

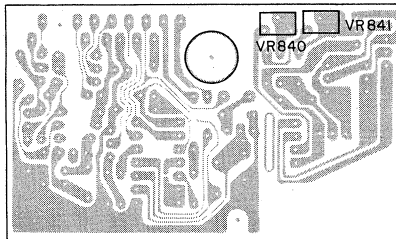

Motor A P. C. Board

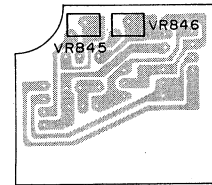

Motor B P. C. Board

Adjustment Procedures

TEST EQUIPMENTS

1. VTVM (Vacuum Tube Voltmeter)
2. Signal Generator
3. Resistance Attenuator
4. Screwdriver
5. Frequency Counter
6. Test Tapes
 MTT-111 (Speed 3kHz)
 MTT-114 (Azimuth 10kHz)
 MTT-150 (Dolby 400Hz Modulation)
 AC-223 (Normal Tape : Blank)
 AC-512 (CrO2 Tape : Blank)
 AC-712 (Metal Tape : Blank)
 MTT-257E, H, J (Response : 10kHz/1kHz)

No.	Adjustment Item	Test Value	Test Tape	Deck A or B	Rec. Volume Control VR802	Switch Position			Adjustable Parts	Test Point	Input Frequency	Equipment/Connection	Remarks
						NR	NR B or C	Input					
1	Head Azimuth Adjustment	Maximum	MTT-114	Both	—	OFF	—	—	Adjusting Screws	TAPE OUT A/B	—	VTVM	Adjust both directions (forward and reverse.) (Fig. 11) Apply lock paint after adjustment.
2	Tape Speed (Normal Speed)	3000±30Hz	MTT-111	Both	—	OFF	—	—	Deck A VR840	TAPE OUT A/B	—	Frequency Counter	Check at the halfway point of the tape length. Adjust both directions : forward and reverse. (Fig.12)
									Deck B VR845				
3	Tape Speed (High Speed)	6000±60Hz	MTT-111	Both	—	OFF	—	—	Deck A VR841	TAPE OUT A/B	—	Frequency Counter	Check at the halfway point of the tape length. Adjust both directions : forward and reverse. Connect base of Q841 (Q846) to GND. (Fig. 12)
									Deck B VR846				
4	Playback Sensitivity Adjustment	500±10mV	MTT-150	Both	—	OFF	—	—	Deck A VR401 (L) VR402 (R) Deck B VR101 (L) VR102 (R)	TAPE OUT A/B	—	See Fig. 13.	Adjust both directions : forward and reverse.
5	Bias Oscillator Frequency Adjustment	105±0.5kHz	AC-223	Deck B	—	OFF	—	—	L209	HOT : TP-1 GND : TP-2	—	See Fig. 14.	Adjust in REC mode.
6	Bias Trap Adjustment	Minimum	AC-223	Deck B	—	OFF	—	—	L ch. L205	HOT : TP-5 GND : TP-7	—	VTVM	Adjust in REC mode.
									R ch. L206	HOT : TP-6 GND : TP-7			
7	Bias Current Adjustment ①	5±0.1mV	AC-223	Deck B	—	OFF	—	—	Lch/Rch VR207/VR208	Lch HOT : TP-1 GND : TP-2 Rch HOT : TP-3 GND : TP-4	—	VTVM	Adjust in REC mode.
		6.5±0.1mV	AC-512						Lch/Rch VR205/VR206				
		12±0.2mV	AC-712						Lch/Rch VR203/VR204				
8	Bias Current Adjustment ②	12±0.2mV	AC-712	Both	—	OFF	—	—	Lch VR201 Rch VR202	Lch HOT : TP-1 GND : TP-2 Rch HOT : TP-3 GND : TP-4	—	VTVM	Adjust in high speed (×2) dubbing mode.
9	Rec Level Meter Sensitivity Adjustment	+3dB	AC-223	Deck B	Adjust for the point where TP12-14/13-14 measure 600mV-1.5dB.	OFF	—	TAPE IN	Lch VR815	Lch HOT : TP-12 GND : TP-14	400Hz Around -20dB	VTVM	After adjusting VR802, adjust VR815/816 so that the +3dB point (□ mark) on the level meter lights dimly.
									Rch VR816	Rch HOT : TP-13 GND : TP-14			
10	Rec/PB Sensitivity Adjustment	245mV-3dB	AC-223	Deck B	Maximum	OFF	—	TAPE IN	Lch VR209	Lch HOT : TP-16 GND : TP-7	400Hz	See Fig. 17.	Adjust TP10-14/11-14 for 245mV first by resistance attenuator. Then adjust VR209/210 so that TP15-7/16-7 measure 245mV-3dB.
									Rch VR210	Rch HOT : TP-15 GND : TP-7			
11	Rec/PB Frequency Response Adjustment ①	0±1dB	AC-223 AC-512 AC-712	Deck B	Maximum	OFF	—	TAPE IN	Lch/Rch VR207/VR208 Lch/Rch VR205/VR206 Lch/Rch VR203/VR204	TAPE OUT A/B	400Hz 10kHz	See Fig. 15.	Adjust TAPE OUT for 500mV-25dB first by resistance attenuator. Then adjust VRs 203-208 so that the rec/play level is 0±1dB.
12	Rec/PB Frequency Response Adjustment ②	0±1dB	Deck A MTT-257E Deck B AC-223	Both	—	OFF	—	—	Lch VR201 Rch VR202	TAPE OUT A/B	400Hz 10kHz	See Fig. 16.	Variation of 10kHz to 1kHz by slight adjustment of VR201 and VR202. High speed dubbing mode.

Measurement Conditions

- Power Supply : AD=220V, UC/UQ=120V
- Input : 0dB=1Vrms ● TAPE IN (Signal Generator Output Impedance) : 600 ohms
- TAPE OUT (Load Impedance) : 47k ohms ● HEADPHONE OUT (Load Impedance) : 8 ohms ● Test Point Load Impedance : No load

Fig. 11 HEAD AZIMUTH ADJUSTMENT

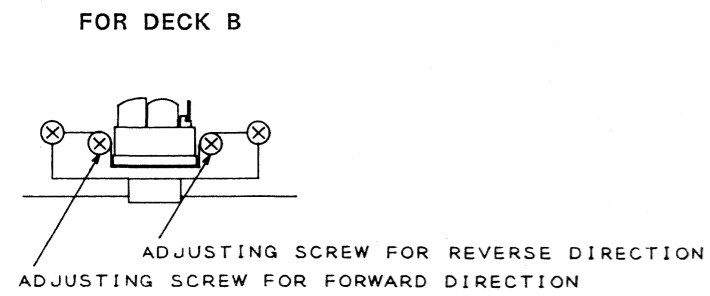
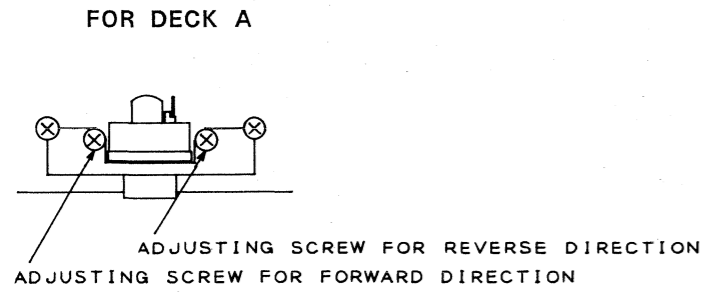

Fig. 12 TAPE SPEED ADJUSTMENT

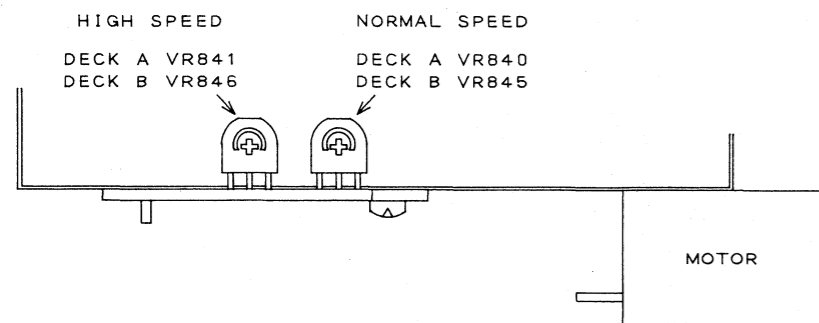

Fig. 13 PLAYBACK SENSITIVITY ADJUSTMENT

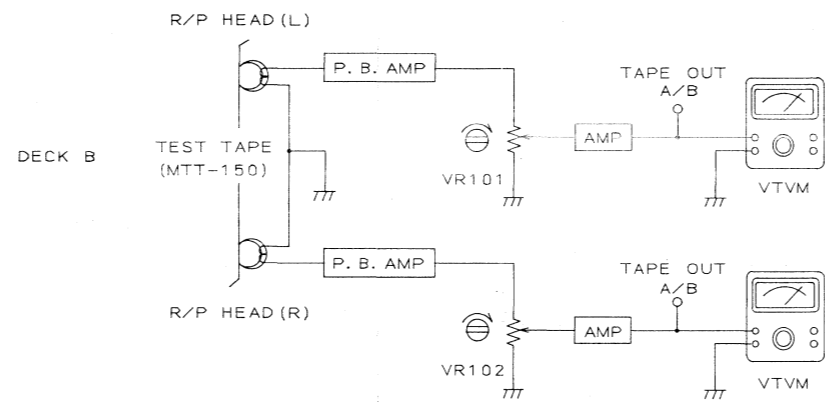
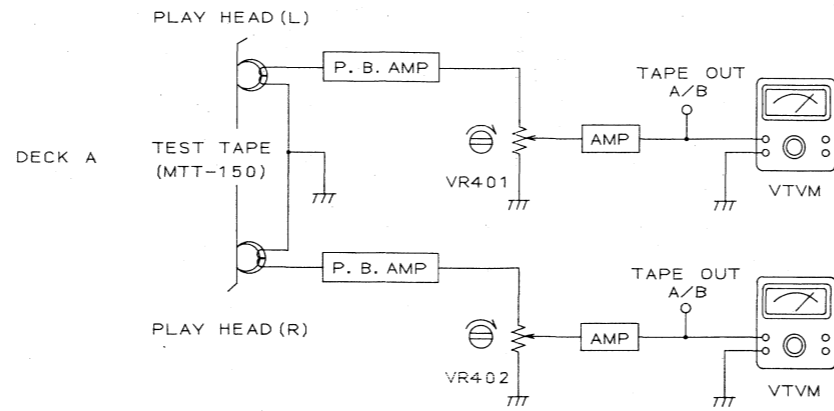

Fig. 14 BIAS OSCILLATOR FREQUENCY ADJUSTMENT

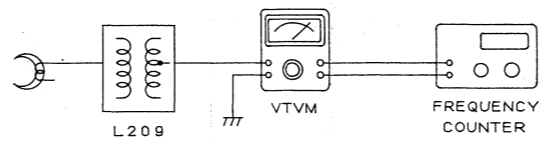

Fig. 15 RECORD/PLAYBACK FREQUENCY RESPONSE ADJUSTMENT

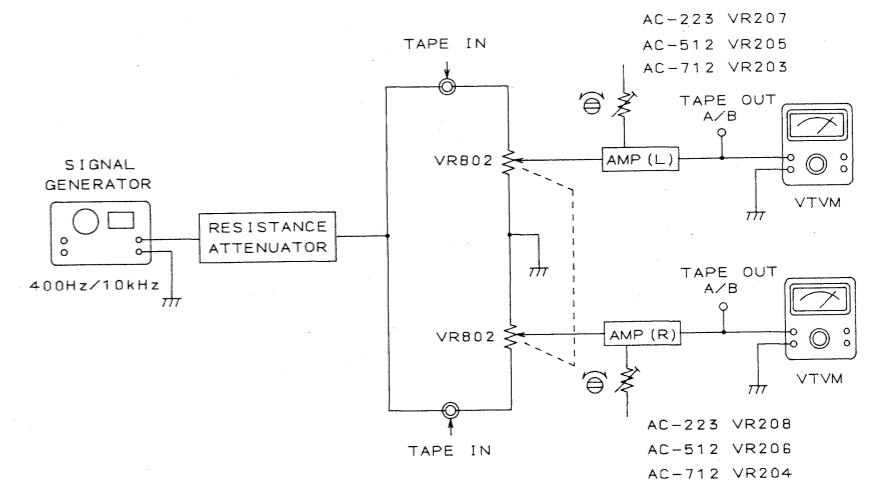

Fig. 16 REC/PB FREQUENCY RESPONSE ADJUSTMENT

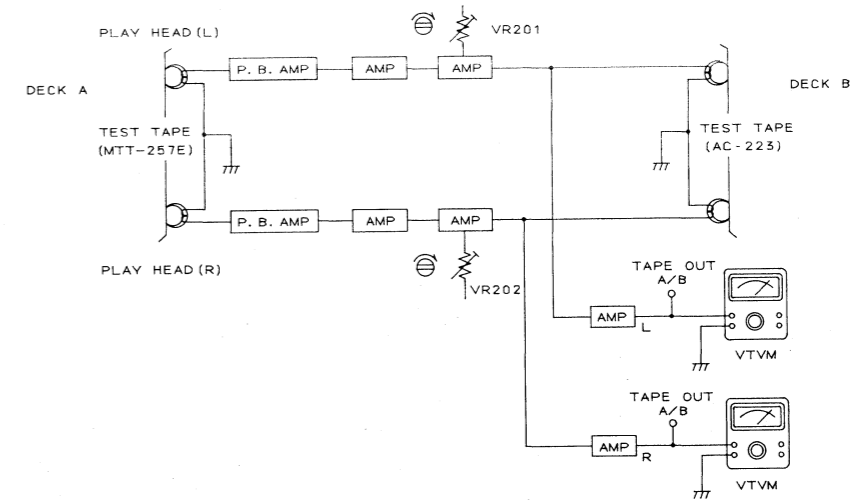
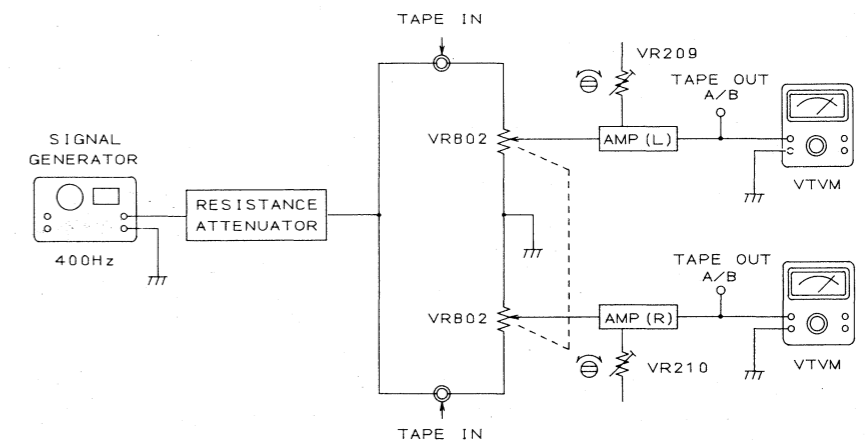

Fig. 17 RECORD/PLAYBACK SENSITIVITY ADJUSTMENT



Parts Layout on P.C. Boards and Wiring Diagram

1

Dolby Switch P.C. Board

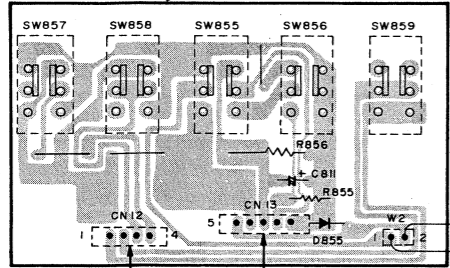

2

Main P.C. Board

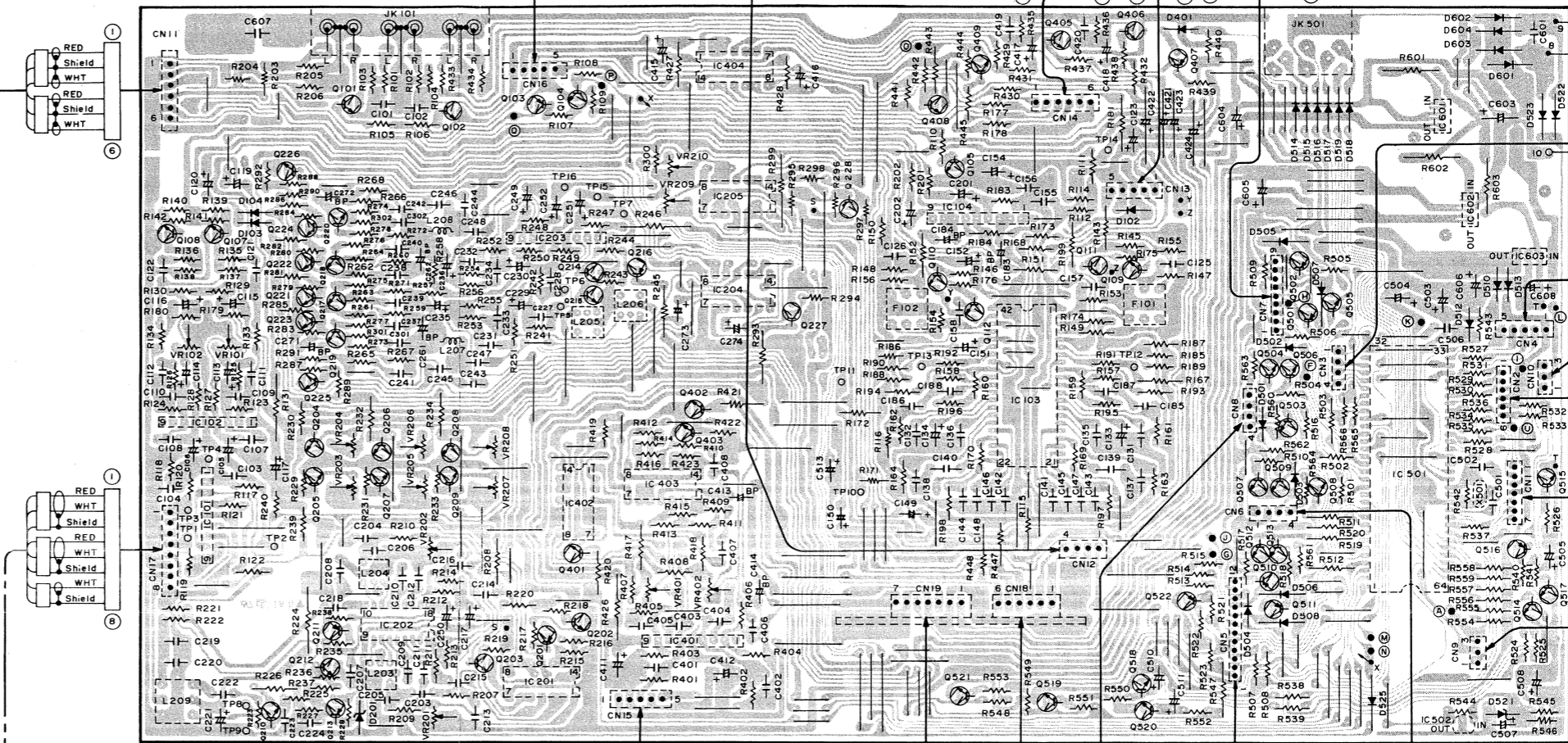

3

Head Phone P.C. Board

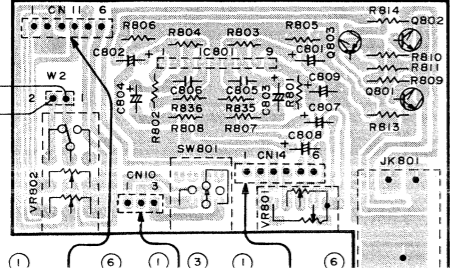

4

Meter P.C. Board

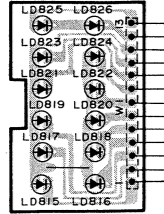

Meter Drive P.C. Board

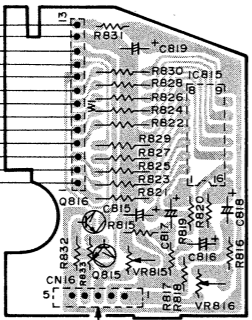

5

Deck A Head HD 701

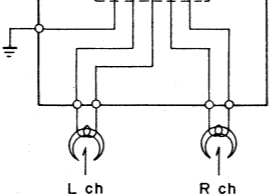

Deck B Head HD 702

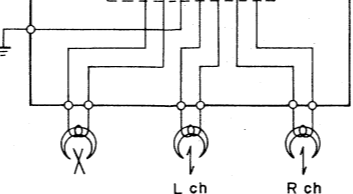

Timer Play

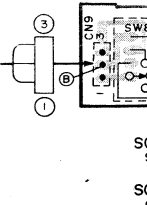

Motor A P.C. Board

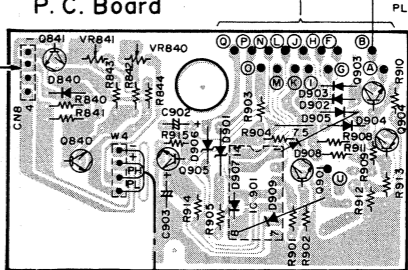

Motor B P.C. Board

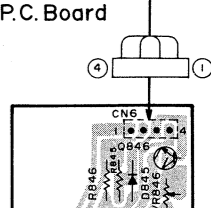

Dolby Play P.C. Board

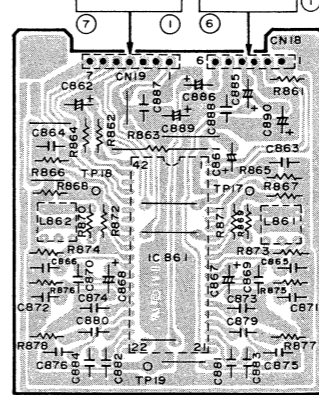

TO EACH CORRESPONDING PIN CONNECTOR (A, B, C, D, E, F, G, H, I, J, K, L, M, N, O, P, Q, R, S, T, U, V, W, X, Y, Z) ON MAIN P.C. BOARD.
TO PIN CONNECTOR (A) ON TIMER PLAY P.C. BOARD.

A

B - 13 -

C

D

E

F - 14 -

G

H

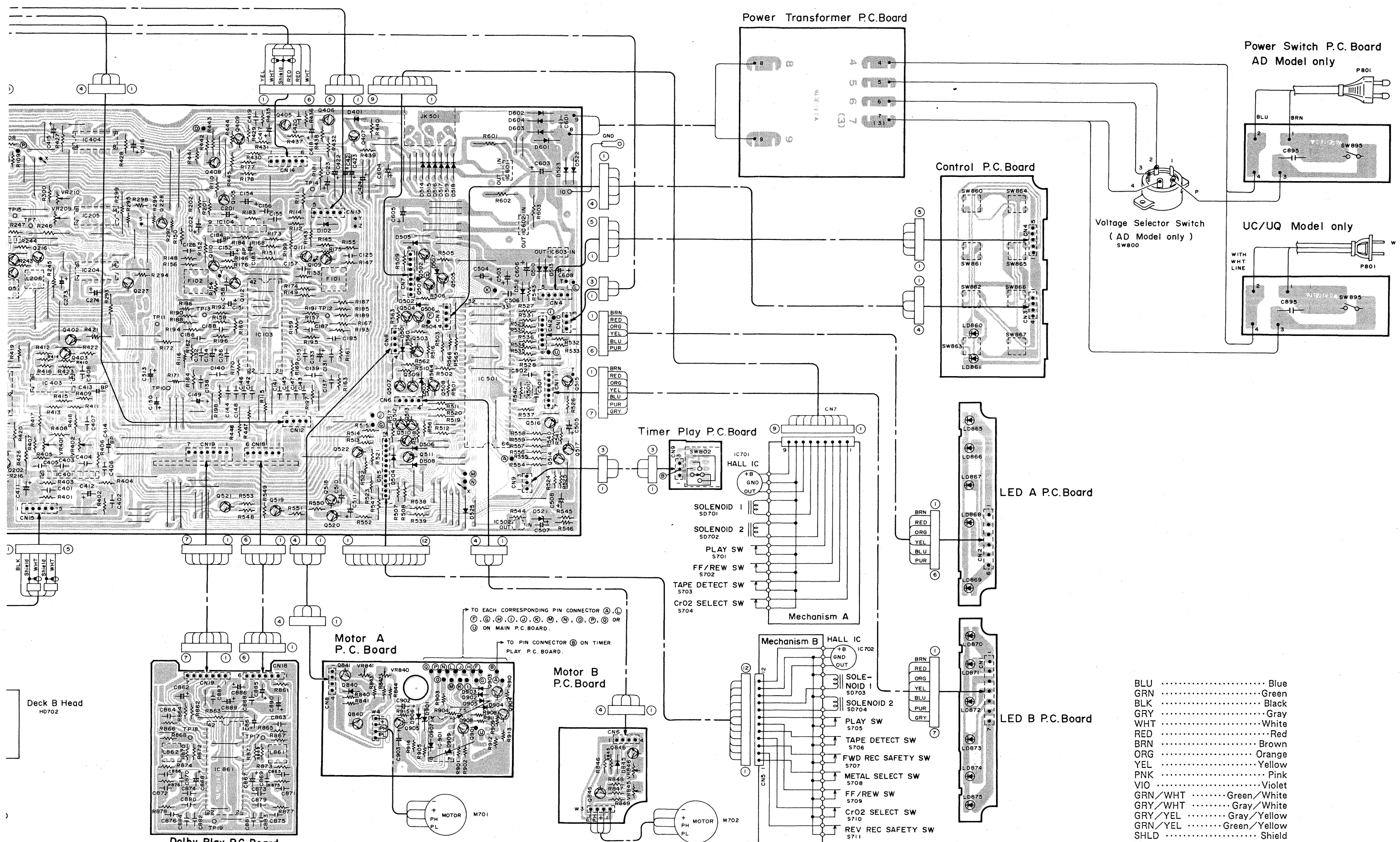

Schematic Diagram (1/2)

IC	IC201	IC101	IC401	IC403	IC202	IC402	IC102	IC404	IC203	IC205	IC501	IC204	IC401~IC603	IC502	IC503	IC504	IC505	IC506	IC507	IC508	IC509	IC510	IC511	IC512	IC513	IC514	IC515	IC516	IC517	IC518	IC519	IC520	IC521	IC522				
TRANSISTOR (Q)	Q402	Q403																																				
	Q201~Q203				Q101~Q104																																	

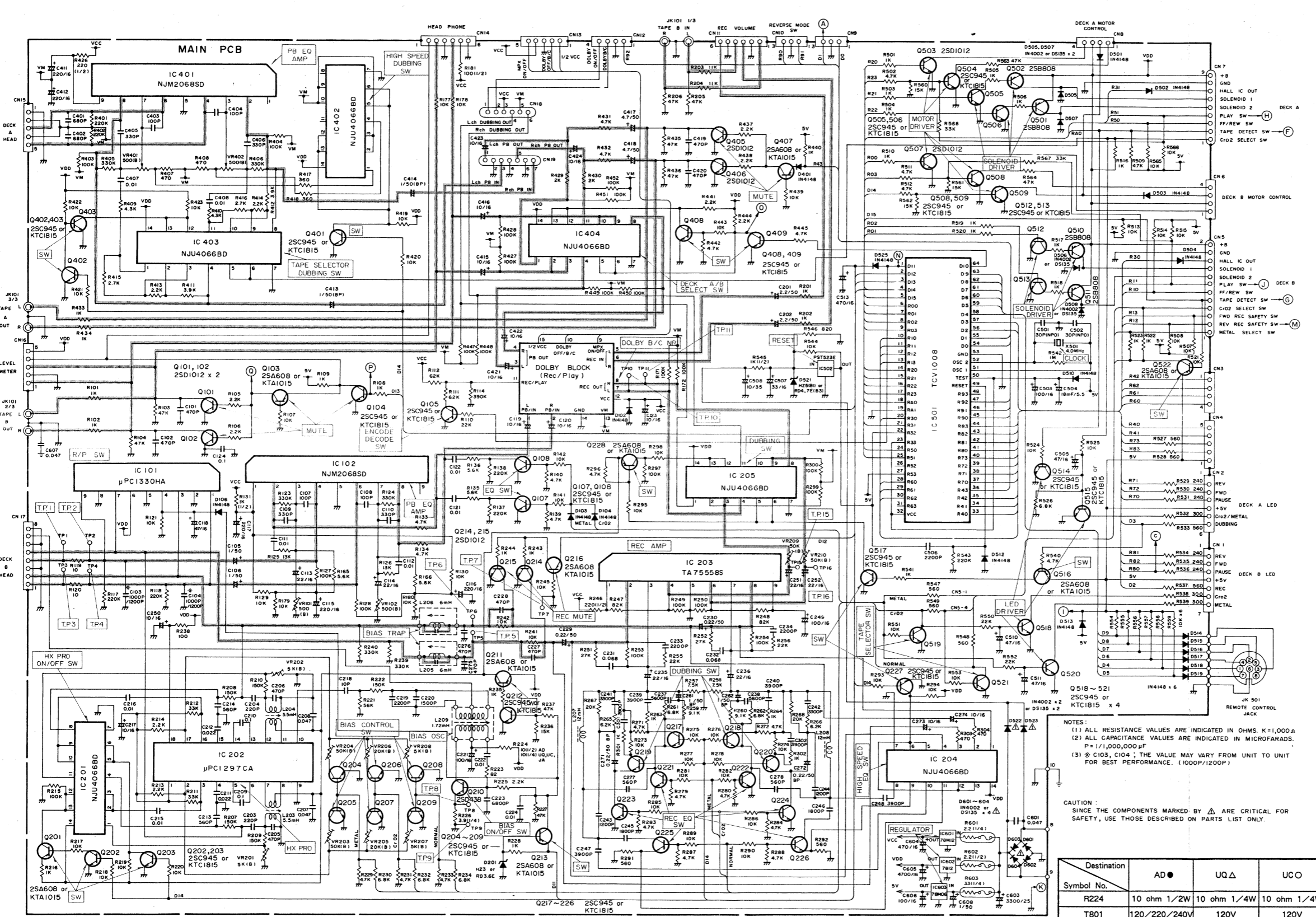

Notes: Power Unit
 ⚡ T
 * T

IC No.	IC101	IC102	IC104	IC203	IC401
Pin No.	REC	Others			
1	0V	0V	7.3V	11.8V	10.9V
2	0V	0V	3.6V	6V	5.9V
3	0V	0V	3.7V	6V	5.9V
4	3.6V	0V	3.6V	5.9V	5.9V
5	0V	0V	0V	0V	0V
6	12V	12V	3.6V	5.9V	5.9V
7	0V	0V	3.7V	6V	5.9V
8	0V	0V	3.6V	6V	5.9V
9	0V	0V	7.3V	11.8V	10.9V

IC No.	REC/Dubbing			High Speed Dubbing		
Pin No.	Normal	C/02	Metal	High Speed Dubbing	Others	Others
1	4.4V	4.4V	4.4V	4.4V	4.4V	
2	1.4V	2.1V	3.5V		1.4V	
3	4.4V	4.4V	4.4V	4.4V	4.4V	
4	2.1V	2.7V	4V		0.6V	
5	1.5V	2.1V	3.5V			
6	2.2V	3V	5V	8.5V	8.6V	
7	12V	12V	12V	12V	0V	
8	12V	12V	12V	12V	0V	
9	0V	0V	0V	0V	0V	
10	1.7V	1.7V	1.7V	1.7V	1.7V	
11	12V	12V	12V	12V	0V	
12	12V	12V	12V	12V	0V	
13	2.2V	3V	5V	8.5V	8.6V	
14	1.5V	2.1V	3.5V			
15	2.1V	2.7V	4V		0.6V	
16	4.4V	4.4V	4.4V	4.4V	4.4V	
17	1.4V	2.1V	3.5V		1.4V	
18	11.3V	11.2V	11V	10.8V	10.9V	

IC No.	Deck B PLAY		Deck B REC		Deck B REC		Deck B REC	
Pin No.	Normal	C/02	Metal	No Tape	Normal	C/02	Metal	No Tape
In	21.3V	20.7V	21.1V	20.2V	18.9V	17.6V	17.6V	
GND	0V	0V	0V	0V	0V	0V	0V	
OUT	12.0V	12.0V	12.0V	12.0V	6.0V	6.0V		

IC101		IC202		IC503	
Deck B PLAY	Deck B REC	Deck B PLAY	Deck B REC	Deck B PLAY	Deck B REC
E	0V	0V	4V	0.1V	0V
C	0V	0V	4V	0V	10V
B	0.7V	0V	3.3V	0V	0.8V

Q201		Q202		Q203	
REC	High Speed Dubbing	Others	REC	High Speed Dubbing	Others
E	12V	11V	0V	0V	0V
C	0V	11V	0V	11.6V	0V
B	11.3V	10.2V	0V	0V	0.7V

Q204, 205		Q206, 207	
Normal	C/02	Metal	No Tape
E	0V	0V	0V
C	1.3V	1.9V	0V
B	0V	0V	0.6V

Q208, 209		Q210		Q211	
Normal	C/02	Metal	No Tape	REC	Others
E	0V	0V	0V	0V	12.1V
C	0V	1.6V	3.3V	4.4V	12.1V
B	0.6V	0V	0V	0.5V	11.3V

Q212		Q213		Q214, 215		Q216	
REC	Others	REC	Others	REC Running	Others	REC Running	Others
E	0V	0V	4.3V	0V	0V	0V	5.2V
C	0V	11.5V	4.2V	0V	0V	0V	5.2V
B	0.7V	0V	3.5V	0V	0V	0.7V	4.5V

Q217, 218		Q219, 220		Q221, 222	
High Speed Dubbing/Normal	High Speed Dubbing/C/02	High Speed Dubbing/Metal	Others	High Speed Dubbing/Normal	High Speed Dubbing/C/02
E	2.9V	1.9V	0V	0V	0V
C	2.9V	1.9V	0V	0V	0V
B	3.5V	2.6V	0.7V	0V	0V

Q223, 224		Q225, 226	
Normal/Metal	C/02	High Speed Dubbing/Normal	High Speed Dubbing/C/02
E	0V	0V	0V
C	0V	0V	2.9V
B	0V	0.6V	0V

NOTES:
 (1) ALL RESISTANCE VALUES ARE INDICATED IN OHMS K=1,000,000
 (2) ALL CAPACITANCE VALUES ARE INDICATED IN MICROFARADS. P=1/10,000,000UF
 (3) * C103, C104; THE VALUE MAY VARY FROM UNIT TO UNIT FOR BEST PERFORMANCE. (1000P/1200P)

CAUTION: SINCE THE COMPONENTS MARKED BY Δ ARE CRITICAL FOR SAFETY, USE THOSE DESCRIBED ON PARTS LIST ONLY.

Destination	AD●	UQΔ	UCO
R224	10 ohm 1/2W	10 ohm 1/4W	10 ohm 1/4W
T801	120/220/240V	120V	120V

1

2

3

4

5

A

B - 16 -

C

D

E

F - 17 -

G

H

Schematic Diagram (2/2)

K-110W

K-110W

IC	IC815	IC801	Q840	Q841	Q845	Q846
TRANSISTOR (Q)	Q803 Q802 Q801	Q816 Q815				

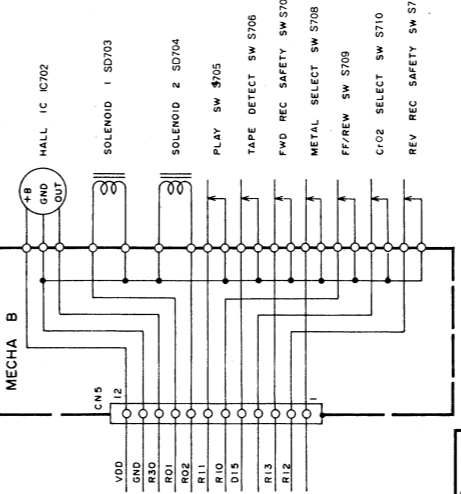
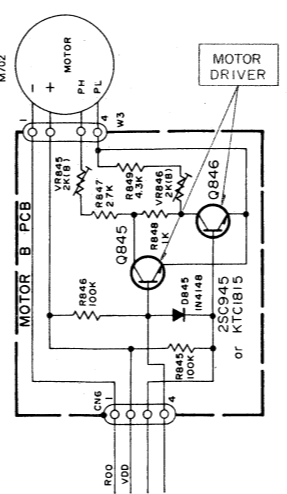
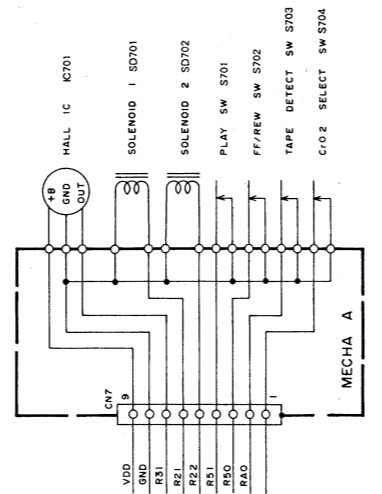
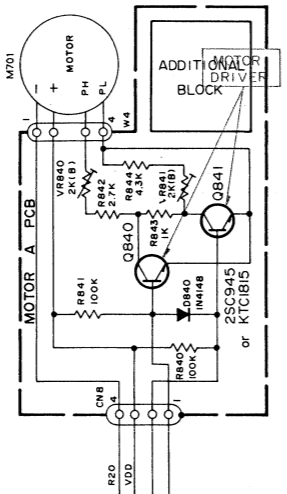
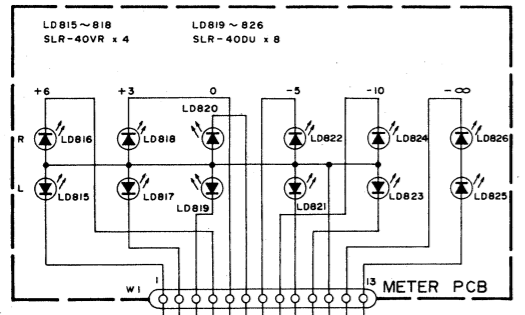

NOTES: (1) ALL RESISTANCE VALUES ARE INDICATED IN OHMS. K=1,000Ω
 (2) ALL CAPACITANCE VALUES ARE INDICATED IN MICROFARADS. P=1/1,000,000 μF

CAUTION: SINCE THE COMPONENTS MARKED BY Δ ARE CRITICAL FOR SAFETY, USE THOSE DESCRIBED ON PARTS LIST ONLY.

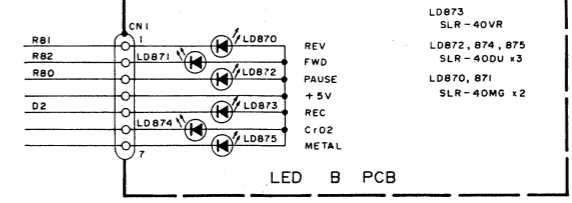
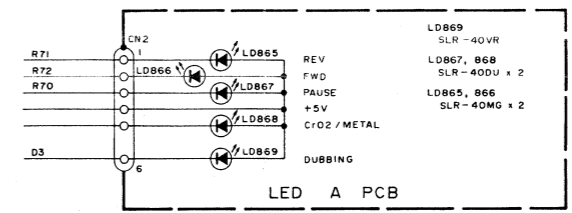
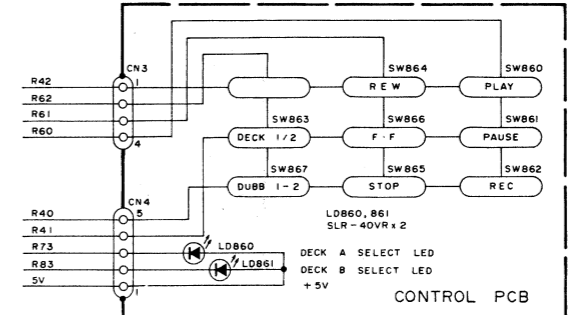
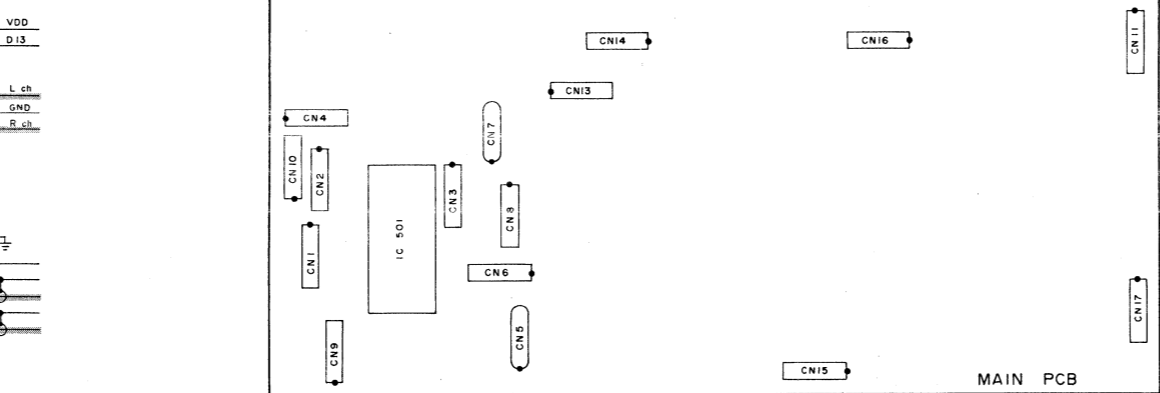
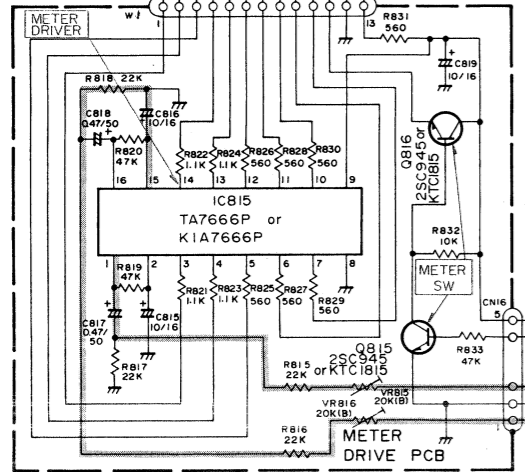

Notes: Power supply voltage: 120V
Unit: Volt
The voltage drops gradually to 0
The voltage varies according to

Q801, 802				Q803				Q815		
FF/REW Stop	Others	FF/REW Stop	Others	Play/REC	Others					
E	0V	0V	4V	0V	E	0V	0V			
C	0V	0V	3.9V	0V	C	12V	0V			
B	0.7V	0V	3.3V	0V	B	0V	0.7V			

Q840					Q841		
Stop	Play	FF/REW	High Speed Dubbing	Stop	Play	FF/REW	
E	12V	8V	7V	4.9V	12V	8V	6.8V
C	12V	8V	8V	8V	12V	8V	6.8V
B	12V	8.6V	0V	1.1V	12V	8.6V	7.7V

Q845					Q846		
Stop	Play	FF/REW	High Speed Dubbing	Stop	Play	FF/REW	
E	12V	8V	7V	4.9V	12V	8V	6.8V
C	12V	8V	8V	8V	12V	8V	6.8V
B	12V	8.6V	0V	1.1V	12V	8.6V	7.7V

IC No.	IC801	IC No.	IC815
Pin No.		Pin No.	
1	10.9V	1	1.4V
2	5.5V	2	1.4V
3	5.5V	3	0V
4	5.5V	4	10.4V
5	0V	5	0V
6	5.5V	6	10.4V
7	5.5V	7	0V
8	5.5V	8	0V
9	10.9V	9	1V
		10	0V
		11	0V
		12	0V
		13	0V
		14	0V
		15	1.4V
		16	1.4V

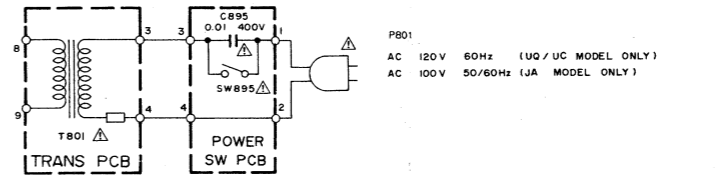
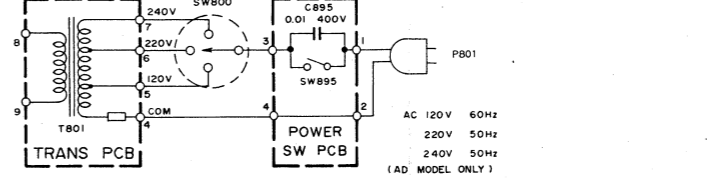
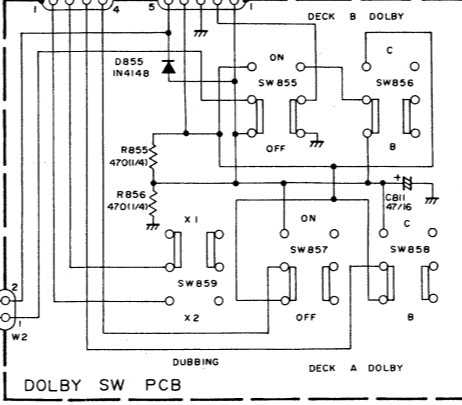
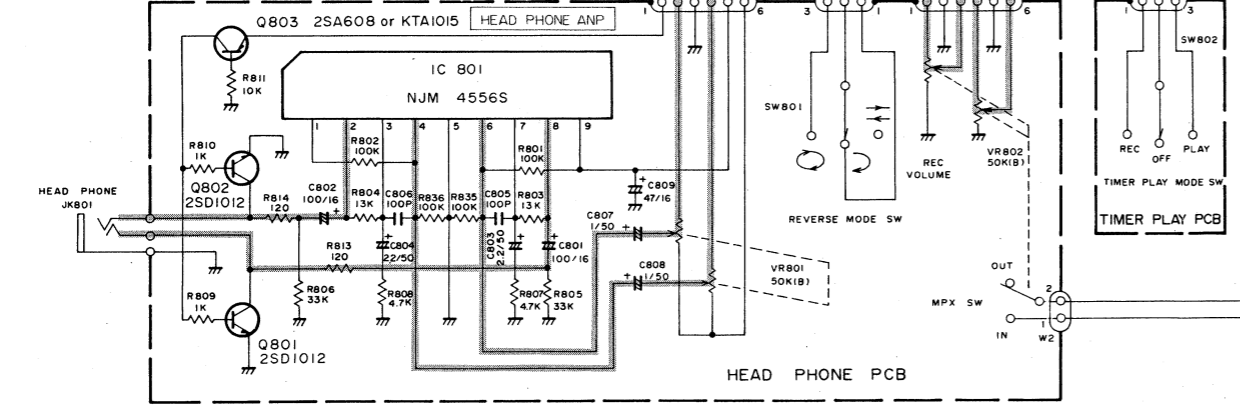
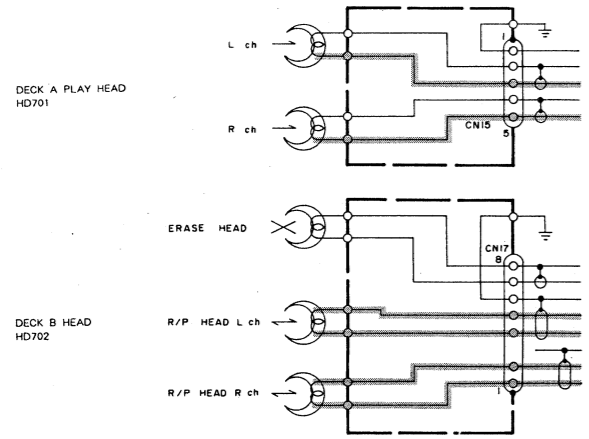

IC	IC901			
TRANSISTOR (Q)	Q903	Q901	Q904	Q905

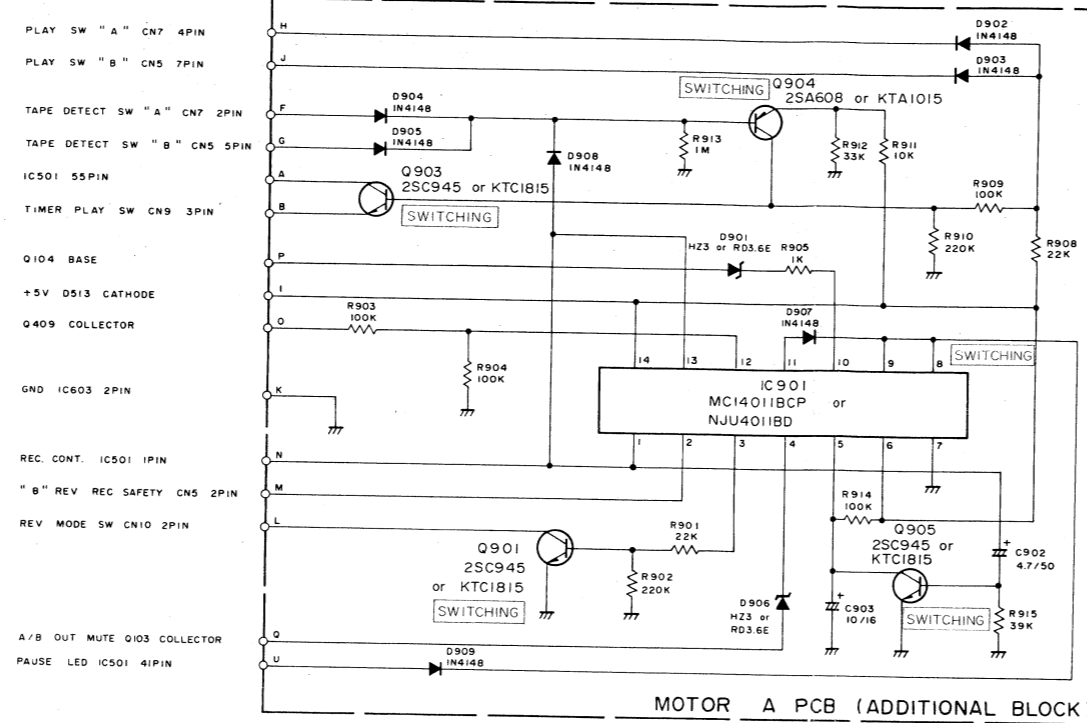

Notes: Power supply voltage: 120V
Unit: Volt
The voltage drops gradually to 0.
The voltage varies according to the tape used.

IC No.	IC901
Pin No.	No Tape
1	0V
2	5.2V
3	5.1V
4	0V
5	5.2V
6	5.2V
7	0V
8	4.9V
9	4.9V
10	0V
11	5.2V
12	*4.9V
13	0V
14	5.2V

* Pin 12 of IC901 is 4.9V when deck B is selected. It is 0V when deck A is selected.

	Q901	**Q903	Q904	Q905
	No Tape			
E	0V	2.9V	4V	0V
C	0V	5.2V	3.3V	5.2V
B	0.7V	3.3V	4.8V	0V

** In timer play mode, Q903 shows the following values: E=0V, C=0V, B=0.7V

Notes: Power supply voltage: 120V
Unit: Volt
The voltage drops gradually to 0.
The voltage varies according to the tape used.

QB01, B02				QB03			
FF/REW Stop	Others	FF/REW Stop	Others	Play/REC	Others	Play/REC	Others
E	0V	0V	4V	0V	0V	11.6V	1V
C	0V	0V	3.9V	0V	12V	0V	12V
B	0.7V	0V	3.3V	0V	0V	0.7V	12V

QB40				QB41				
Stop	Play	FF/REW	High Speed Dubbing	Stop	Play	FF/REW	High Speed Dubbing	
E	12V	8V	7V	4.9V	12V	8V	6.8V	5.1V
C	12V	8V	8V	8V	12V	8V	6.8V	7.1V
B	12V	8.6V	9V	1.1V	12V	8.6V	7.7V	0.6V

QB45				QB46				
Stop	Play	FF/REW	High Speed Dubbing	Stop	Play	FF/REW	High Speed Dubbing	
E	12V	8V	7V	4.9V	12V	8V	6.8V	5.1V
C	12V	8V	8V	8V	12V	8V	6.8V	7.1V
B	12V	8.6V	9V	1.1V	12V	8.6V	7.7V	0.6V

IC No.	IC801
Pin No.	No. Signal
1	10.9V
2	5.5V
3	5.5V
4	5.5V
5	0V
6	5.5V
7	5.5V
8	5.5V
9	10.9V

IC No.	IC815	
Pin No.	STOP/FF/REW	Others
1	1.4V	1.4V
2	1.4V	1.4V
3	0V	10.4V
4	0V	10.4V
5	0V	10.4V
6	0V	10.4V
7	0V	10.4V
8	0V	0V
9	1V	12V
10	0V	10.4V
11	0V	10.4V
12	0V	10.4V
13	0V	10.4V
14	0V	10.4V
15	1.4V	1.4V
16	1.4V	1.4V

NOTES: (1) ALL RESISTANCE VALUES ARE INDICATED IN OHMS. K = 1,000 Ω.
(2) ALL CAPACITANCE VALUES ARE INDICATED IN MICROFARADS.
P = 1/1,000,000 μF.

BEFORE RETURNING THE SET TO THE CUSTOMER, MAKE APPROPRIATE LEAKAGE CURRENT OR RESISTANCE MEASUREMENTS TO DETERMINE THAT EXPOSED PARTS ARE PROPERLY INSULATED FROM THE SUPPLY CIRCUIT.

CAUTION: SINCE THE COMPONENTS MARKED BY Δ ARE CRITICAL FOR SAFETY, USE THOSE DESCRIBED ON PARTS LIST ONLY.

Electrical Parts List

Resistor : Carbon resistors under 1/6 watts are not mentioned in the parts list, please confirm them by schematic diagram.

Capacitor : μ F=microfarads, pF=picofarads

Abbreviations					Symbol No.	Part No.	Description		
RES.= Resistor	CAP.= Capacitor				Q109	48E05541S01	2SD1012		
C.F.= Carbon Film	ELY.= Electrolytic				Q110	48E05541S01	2SD1012		
M.F.= Metal Film	CER.= Ceramic				Q111	48E05542S01	2SC945		
M.O.= Metal Oxide Film	MYL.= Mylar				or	48E04784S01	KTC1815		
M.P.= Metal Plate	TAN.= Tantalum				Q112	48E05542S01	2SC945		
TR.= Transistor	POLY.= Polystyrol				or	48E04784S01	KTC1815		
TRANS.= Transformer	PP.= Polypropylene				Q201	48T65363F02	2SA608		
CP.= Chip	PLT.= Polyethylene				or	48E04785S01	KTA1015		
	B.P.= Bi Polar				Q202	48E05542S01	2SC945		
					or	48E04784S01	KTC1815		
Symbol No.	Part No.	Description			Q203	48E05542S01	2SC945		
Main P. C. Board					or	48E04784S01	KTC1815		
IC's					Q204	48E05542S01	2SC945		
IC101	51E05529S01	μ PC1330HA			or	48E04784S01	KTC1815		
IC102	51T73021F02	NJM2068SD			Q205	48E05542S01	2SC945		
IC103	51E05530S01	CX20188			or	48E04784S01	KTC1815		
IC104	51E05531S01	NJM4558S (D)			Q206	48E05542S01	2SC945		
IC201	51E05532S01	NJU4066BD			or	48E04784S01	KTC1815		
IC202	51T72929F01	μ PC1297CA			Q207	48E05542S01	2SC945		
IC203	51E05533S01	TA75558S			or	48E04784S01	KTC1815		
IC204	51E05532S01	NJU4066BD			Q208	48E05542S01	2SC945		
IC205	51E05532S01	NJU4066BD			or	48E04784S01	KTC1815		
IC401	51T73021F02	NJM2068SD			Q209	48E05542S01	2SC945		
					or	48E04784S01	KTC1815		
IC402	51E05532S01	NJU4066BD			Q210	48T58776F02	2SD438		
IC403	51E05532S01	NJU4066BD			Q211	48T65363F02	2SA608		
IC404	51E05532S01	NJU4066BD			or	48E04785S01	KTA1015		
IC501	51E05534S01	TCV1008			Q212	48E05542S01	2SC945		
IC502	51E05535S01	PST523E			or	48E04784S01	KTC1815		
IC601	51E05536S01	MC78M12CT			Q213	48T65363F02	2SA608		
IC602	51T94884F04	MC7812CT			or	48E04785S01	KTA1015		
IC603	51E05537S01	MC78M06CT			Q214	48E05541S01	2SD1012		
					Q215	48E05541S01	2SD1012		
					Q216	48T65363F02	2SA608		
					or	48E04785S01	KTA1015		
					Q217	48E05542S01	2SC945		
					or	48E04784S01	KTC1815		
					Q218	48E05542S01	2SC945		
					or	48E04784S01	KTC1815		
					Q219	48E05542S01	2SC945		
					or	48E04784S01	KTC1815		
					Q220	48E05542S01	2SC945		
					or	48E04784S01	KTC1815		
					Q221	48E05542S01	2SC945		
					or	48E04784S01	KTC1815		
					Q222	48E05542S01	2SC945		
					or	48E04784S01	KTC1815		
Transistors									
Q101	48E05541S01	2SD1012							
Q102	48E05541S01	2SD1012							
Q103	48T65363F02	2SA608							
or	48E04785S01	KTA1015							
Q104	48E05542S01	2SC945							
or	48E04784S01	KTC1815							
Q105	48E05542S01	2SC945							
or	48E04784S01	KTC1815							
Q107	48E05542S01	2SC945							
or	48E04784S01	KTC1815							
Q108	48E05542S01	2SC945							
or	48E04784S01	KTC1815							

Symbol No.	Part No.	Description			Symbol No.	Part No.	Description		
Q223	48E05542S01	2SC945			Q517	48E05542S01	2SC945		
or	48E04784S01	KTC1815			or	48E04784S01	KTC1815		
Q224	48E05542S01	2SC945			Q518	48E05542S01	2SC945		
or	48E04784S01	KTC1815			or	48E04784S01	KTC1815		
Q225	48E05542S01	2SC945			Q519	48E05542S01	2SC945		
or	48E04784S01	KTC1815			or	48E04784S01	KTC1815		
Q226	48E05542S01	2SC945			Q520	48E05542S01	2SC945		
or	48E04784S01	KTC1815			or	48E04784S01	KTC1815		
Q227	48E05542S01	2SC945			Q521	48E05542S01	2SC945		
or	48E04784S01	KTC1815			or	48E04784S01	KTC1815		
Q228	48T65363F02	2SA608			Q522	48T65363F02	2SA608		
or	48E04785S01	KTA1015			or	48E04785S01	KTA1015		
Q401	48E05542S01	2SC945			Diodes				
or	48E04784S01	KTC1815			D102	48E04616S01	Silicon, 1N4148		
Q402	48E05542S01	2SC945			D103	48E04616S01	Silicon, 1N4148		
or	48E04784S01	KTC1815			D104	48E04616S01	Silicon, 1N4148		
Q403	48E05542S01	2SC945			D106	48E04616S01	Silicon, 1N4148		
or	48E04784S01	KTC1815			D201	48T52739F15	Zener, HZ3		
Q405	48E05541S01	2SD1012			or	48T40732F08	Zener, RD3.6E		
Q406	48E05541S01	2SD1012			D401	48E04616S01	Silicon, 1N4148		
Q407	48T65363F02	2SA608			D501	48E04616S01	Silicon, 1N4148		
or	48E04785S01	KTA1015			D502	48E04616S01	Silicon, 1N4148		
Q408	48E05542S01	2SC945			D503	48E04616S01	Silicon, 1N4148		
or	48E04784S01	KTC1815			D504	48E04616S01	Silicon, 1N4148		
Q409	48E05542S01	2SC945			D505	48S40477U02	Silicon, 1N4002		
or	48E04784S01	KTC1815			or	48T44992F01	Silicon, DS135D		
Q501	48E05543S01	2SB808			D506	48S40477U02	Silicon, 1N4002		
Q502	48E05543S01	2SB808			or	48T44992F01	Silicon, DS135D		
Q503	48E05541S01	2SD1012			D507	48S40477U02	Silicon, 1N4002		
Q504	48E05542S01	2SC945			or	48T44992F01	Silicon, DS135D		
or	48E04784S01	KTC1815			D508	48S40477U02	Silicon, 1N4002		
Q505	48E05542S01	2SC945			or	48T44992F01	Silicon, DS135D		
or	48E04784S01	KTC1815			D510	48E04616S01	Silicon, 1N4148		
Q506	48E05542S01	2SC945			D512	48E04616S01	Silicon, 1N4148		
or	48E04784S01	KTC1815			D513	48E04616S01	Silicon, 1N4148		
Q507	48E05541S01	2SD1012			D514	48E04616S01	Silicon, 1N4148		
Q508	48E05542S01	2SC945			D515	48E04616S01	Silicon, 1N4148		
or	48E04784S01	KTC1815			D516	48E04616S01	Silicon, 1N4148		
Q509	48E05542S01	2SC945			D517	48E04616S01	Silicon, 1N4148		
or	48E04784S01	KTC1815			D518	48E04616S01	Silicon, 1N4148		
Q510	48E05543S01	2SB808			D519	48E04616S01	Silicon, 1N4148		
Q511	48E05543S01	2SB808			D521	48T52739F28	Zener, HZ5		
Q512	48E05542S01	2SC945			or	48T56372F21	Zener, RD4.7E		
or	48E04784S01	KTC1815			D522	48S40477U02	Silicon, 1N4002		
Q513	48E05542S01	2SC945			or	48T44992F01	Silicon, DS135D		
or	48E04784S01	KTC1815			D523	48S40477U02	Silicon, 1N4002		
Q514	48E05542S01	2SC945			or	48T44992F01	Silicon, DS135D		
or	48E04784S01	KTC1815			D525	48E04616S01	Silicon, 1N4148		
Q515	48E05542S01	2SC945			D601	48S40477U02	Silicon, 1N4002		
or	48E04784S01	KTC1815			or	48T44992F01	Silicon, DS135D		
Q516	48T65363F02	2SA608							
or	48E04785S01	KTA1015							

Symbol No.	Part No.	Description			Symbol No.	Part No.	Description		
D602 or D603 or D604 or	48S40477U02 48T44992F01 48S40477U02 48T44992F01 48S40477U02 48T44992F01	Silicon, 1N4002 Silicon, DS135D Silicon, 1N4002 Silicon, DS135D Silicon, 1N4002 Silicon, DS135D			C115 C116 C117 C118 C119	23E04754S02 23E04754S02 23E04754S02 23E04754S05 23E04754S01	ELY., 220 μ F/16V ELY., 220 μ F/16V ELY., 220 μ F/16V ELY., 47 μ F/16V ELY., 10 μ F/16V		
Coils/Inductors					C120 C121 C122 C123 C124	23E04754S01 08E04735S05 08E04735S05 23E04754S01 21E04631S05	ELY., 10 μ F/16V MYL., 0.01 μ F MYL., 0.01 μ F ELY., 10 μ F/16V CER., 0.1 μ F		
L203 L204 L205 L206 L207	24E05524S01 24E05524S01 24E05525S01 24E05525S01 24E05526S01	5.5mH 5.5mH 6mH 6mH Inductor, 12mH			C125 C126 C131 C132 C133	21E04638S05 21E04638S05 08E04735S07 08E04735S07 23E04635S04	CER., 820pF CER., 820pF MYL., 3900pF MYL., 3900pF ELY., 0.47 μ F/50V		
L208 L209	24E05526S01 24E05527S01	Inductor, 12mH 1.72mH			C134 C135 C136 C137 C138	23E04635S04 08E05500S01 08E05500S01 08E04735S06 08E04735S06	ELY., 0.47 μ F/50V MYL., 0.15 μ F MYL., 0.15 μ F MYL., 0.015 μ F MYL., 0.015 μ F		
Filters					C139 C140 C141 C142 C143	08E05500S02 08E05500S02 08E05500S03 08E05500S03 08E05500S04	MYL., 0.22 μ F MYL., 0.22 μ F MYL., 0.068 μ F MYL., 0.068 μ F MYL., 0.056 μ F		
FT101 FT102	91E05528S01 91E05528S01	10PD MPX 10PD MPX			C144 C145 C146 C147 C148	08E05500S04 08E04735S08 08E04735S08 08E04735S05 08E04735S05	MYL., 0.056 μ F MYL., 5600pF MYL., 5600pF MYL., 0.01 μ F MYL., 0.01 μ F		
Jacks					C149 C150 C151 C152 C154	23E04754S04 23E04754S04 23E04754S01 23E04635S07 23E06052S01	ELY., 22 μ F/16V ELY., 22 μ F/16V ELY., 10 μ F/16V ELY., 4.7 μ F/50V ELY., 1000 μ F/10V		
JK101 JK501	09E04620S01 09E05502S01	RCA Jack DIN Jack (Remote)			C155 C156 C157 C158 C183	08E04735S09 08E04735S09 08E04735S10 08E04735S10 23E05501S01	MYL., 0.022 μ F MYL., 0.022 μ F MYL., 2700pF MYL., 2700pF ELY., 10 μ F/50V (B.P.)		
Resonator					C184 C185 C186 C187 C188	23E05501S01 08E04735S11 08E04735S11 08E04735S11 08E04735S11	ELY., 10 μ F/50V (B.P.) MYL., 2200pF MYL., 2200pF MYL., 2200pF MYL., 2200pF		
X501	48E05503S01	4MHz			C201 C202 C203 C204 C205	23E04635S08 23E04635S08 21E04638S06 21E04638S06 21E04734S06	ELY., 2.2 μ F/50V ELY., 2.2 μ F/50V CER., 220pF CER., 220pF CER., 470pF		
Capacitors					C101 C102 * C103 * C103 * C104 * C104 C105 C106 C107 C108 C109 C110 C111 C112 C113 C114	21E04638S02 21E04638S02 08E04735S14 08E04735S04 08E04735S14 08E04735S04 23E04635S03 23E04635S03 21E04638S03 21E04638S03 21E04638S04 21E04638S04 08E04735S05 08E04735S05 23E04754S04 23E04754S04	CER., 470pF CER., 470pF MYL., 1200pF MYL., 1000pF MYL., 1200pF MYL., 1000pF ELY., 1 μ F/50V ELY., 1 μ F/50V CER., 100pF CER., 100pF CER., 330pF CER., 330pF MYL., 0.01 μ F MYL., 0.01 μ F ELY., 22 μ F/16V ELY., 22 μ F/16V		

Note : * Either 1200pF or 1000pF is used for C103 and C104 for proper adjustment.

Symbol No.	Part No.	Description			Symbol No.	Part No.	Description		
C206	21E04734S06	CER., 470pF			C261	23E05501S02	ELY., 1 μ F/50V (B.P.)		
C207	21E05504S01	CER., 0.047 μ F			C262	23E05501S02	ELY., 1 μ F/50V (B.P.)		
C208	21E05504S01	CER., 0.047 μ F			C271	23E05501S03	ELY., 0.22 μ F/50V (B.P.)		
C209	21E04738S01	CER., 0.1 μ F			C272	23E05501S03	ELY., 0.22 μ F/50V (B.P.)		
C210	21E04738S01	CER., 0.1 μ F			C273	23E04754S01	ELY., 10 μ F/16V		
C211	08E04735S09	MYL., 0.022 μ F			C274	23E04754S01	ELY., 10 μ F/16V		
C212	08E04735S09	MYL., 0.022 μ F			C275	21E04734S04	CER., 470pF		
C213	21E04638S07	CER., 560pF			C276	21E04734S04	CER., 470pF		
C214	21E04638S07	CER., 560pF			C277	21E04734S05	CER., 560pF		
C215	08E04735S05	MYL., 0.01 μ F			C278	21E04734S05	CER., 560pF		
C216	08E04735S05	MYL., 0.01 μ F			C301	08E04735S07	MYL., 3900pF		
C217	23E04754S01	ELY., 10 μ F/16V			C302	08E04735S07	MYL., 3900pF		
C218	21E04734S01	CER., 10pF			C401	21E04638S08	CER., 680pF		
C219	08E05505S01	PP., 2200pF			C402	21E04638S08	CER., 680pF		
C220	08E05505S02	PP., 1500pF			C403	21E04638S03	CER., 100pF		
C221	23E04754S03	ELY., 100 μ F/16V			C404	21E04638S03	CER., 100pF		
C222	08E04735S05	MYL., 0.01 μ F			C405	21E04638S04	CER., 330pF		
C223	08E04735S12	MYL., 6800pF			C406	21E04638S04	CER., 330pF		
C224	08E04735S05	MYL., 0.01 μ F			C407	08E04735S05	MYL., 0.01 μ F		
C227	21E04638S02	CER., 470pF			C408	08E04735S05	MYL., 0.01 μ F		
C228	21E04638S02	CER., 470pF			C411	23E04754S02	ELY., 220 μ F/16V		
C229	23E04635S05	ELY., 0.22 μ F/50V			C412	23E04754S02	ELY., 220 μ F/16V		
C230	23E04635S05	ELY., 0.22 μ F/50V			C413	23E05501S02	ELY., 1 μ F/50V (B.P.)		
C231	08E04735S03	MYL., 0.068 μ F			C414	23E05501S02	ELY., 1 μ F/50V (B.P.)		
C232	08E04735S03	MYL., 0.068 μ F			C415	23E04754S01	ELY., 10 μ F/16V		
C233	08E04735S11	MYL., 2200pF			C416	23E04754S01	ELY., 10 μ F/16V		
C234	08E04735S11	MYL., 2200pF			C417	23E04635S07	ELY., 4.7 μ F/50V		
C235	23E04754S04	ELY., 22 μ F/16V			C418	23E04635S07	ELY., 4.7 μ F/50V		
C236	23E04754S04	ELY., 22 μ F/16V			C419	21E04638S02	CER., 470pF		
C237	08E04735S08	MYL., 5600pF			C420	21E04638S02	CER., 470pF		
C238	08E04735S08	MYL., 5600pF			C421	23E04754S01	ELY., 10 μ F/16V		
C239	08E04735S07	MYL., 3900pF			C422	23E04754S01	ELY., 10 μ F/16V		
C240	08E04735S07	MYL., 3900pF			C423	23E04754S01	ELY., 10 μ F/16V		
C241	08E04735S13	MYL., 3300pF			C424	23E04754S01	ELY., 10 μ F/16V		
C242	08E04735S13	MYL., 3300pF			C501	21E04736S06	CER., NPO, 30pF		
C243	08E04735S14	MYL., 1200pF			C502	21E04736S06	CER., NPO, 30pF		
C244	08E04735S14	MYL., 1200pF			C503	23E04754S03	ELY., 100 μ F/16V		
C245	08E04735S15	MYL., 1800pF			C504	23E04740S02	ELY., 18mF/5.5V		
C246	08E04735S15	MYL., 1800pF			C505	23E04754S05	ELY., 47 μ F/16V		
C247	08E04735S07	MYL., 3900pF			C506	08E04735S17	MYL., 2200pF		
C248	08E04735S07	MYL., 3900pF			C507	23E04754S08	ELY., 33 μ F/16V		
C249	23E04754S03	ELY., 100 μ F/16V			C508	23E04731S02	ELY., 10 μ F/35V		
C250	23E04754S01	ELY., 10 μ F/16V			C510	23E04754S05	ELY., 47 μ F/16V		
C251	23E04754S04	ELY., 22 μ F/16V			C511	23E04754S05	ELY., 47 μ F/16V		
C252	23E04754S04	ELY., 22 μ F/16V			C513	23E04754S06	ELY., 470 μ F/16V		

Symbol No.	Part No.	Description			Symbol No.	Part No.	Description		
C601	21E05506S01	CER., 0.047 μ F			VR401	18E05510S01	Semi-fixed 500B		
C603	23E04636S03	ELY., 3300 μ F/25V			or	18E05511S01	Semi-fixed 500B		
C604	23E04754S06	ELY., 470 μ F/16V			VR402	18E05510S01	Semi-fixed 500B		
C605	23E04754S07	ELY., 4700 μ F/16V			or	18E05511S01	Semi-fixed 500B		
C606	23E04754S03	ELY., 100 μ F/16V			Power SW P. C. Board				
C607	21E04631S04	CER., 0.047 μ F			Switch/Capacitor				
C608	23E04635S03	ELY., 1 μ F/50V			S895	40E04667S01	Switch, Push		
Resistors					C895	08E04663S01	CAP., Line, 0.01 μ F/400V		
R115	06E05544S01	C.F., 470 ohm 1/4W			LED A P. C. Board				
R116	06E05544S01	C.F., 470 ohm 1/4W			LED's				
R131	06E05508S03	C.F., 1k ohm 1/2W			LD865	48E05512S01	Green		
R181	06E05508S04	C.F., 100 ohm 1/2W			LD866	48E05512S01	Green		
● R224	06E05508S01	C.F., 10 ohm 1/2W			LD867	48E05513S01	Orange		
○ R224	06E06053S01	C.F., 10 ohm 1/4W			LD868	48E05513S01	Orange		
△ R224	06E06053S01	C.F., 10 ohm 1/4W			LD869	48E05514S01	Red		
R226	06E05507S01	C.F., 3.9 ohm 1/4W			LED B P. C. Board				
R246	06E05508S02	C.F., 220 ohm 1/2W			LED's				
R426	06E05508S02	C.F., 220 ohm 1/2W			LD870	48E05512S01	Green		
R545	06E05508S03	C.F., 1k ohm 1/2W			LD871	48E05512S01	Green		
R601	06E05509S01	Fuse, 2.2 ohm 1/4W			LD872	48E05513S01	Orange		
R602	06E05546S01	Fuse, 2.2 ohm 1/2W			LD873	48E05514S01	Red		
R603	06E05509S02	Fuse, 33 ohm 1/4W			LD874	48E05513S01	Orange		
VR101	18E05510S01	Semi-fixed 500B			LD875	48E05513S01	Orange		
or	18E05511S01	Semi-fixed 500B			Meter Drive P. C. Board				
VR102	18E05510S01	Semi-fixed 500B			IC				
or	18E05511S01	Semi-fixed 500B			IC815	51E05538S01	TA7666P		
VR201	18E05510S02	Semi-fixed 5kB			or	51E05547S01	KIA7666P		
or	18E05511S02	Semi-fixed 5kB			Transistors				
VR202	18E05510S02	Semi-fixed 5kB			Q815	48E05542S01	2SC945		
or	18E05511S02	Semi-fixed 5kB			or	48E04784S01	KTC1815		
VR203	18E05510S03	Semi-fixed 50kB			Q816	48E05542S01	2SC945		
or	18E05511S03	Semi-fixed 50kB			or	48E04784S01	KTC1815		
VR204	18E05510S03	Semi-fixed 50kB							
or	18E05511S03	Semi-fixed 50kB							
VR205	18E05510S04	Semi-fixed 20kB							
or	18E05511S04	Semi-fixed 20kB							
VR206	18E05510S04	Semi-fixed 20kB							
or	18E05511S04	Semi-fixed 20kB							
VR207	18E05510S02	Semi-fixed 5kB							
or	18E05511S02	Semi-fixed 5kB							
VR208	18E05510S02	Semi-fixed 5kB							
or	18E05511S02	Semi-fixed 5kB							
VR209	18E05510S03	Semi-fixed 50kB							
or	18E05511S03	Semi-fixed 50kB							
VR210	18E05510S03	Semi-fixed 50kB							
or	18E05511S03	Semi-fixed 50kB							

Note : ● : For multivoltage mode (AD), ○ : For USA model (UC),
 △ : For Canadian model (UQ), Others : Common.

Symbol No.	Part No.	Description		
Capacitors				
C815	23E04754S01	ELY., 10 μ F/16V		
C816	23E04754S01	ELY., 10 μ F/16V		
C817	23E04635S04	ELY., 0.47 μ F/50V		
C818	23E04635S04	ELY., 0.47 μ F/50V		
C819	23E04754S01	ELY., 10 μ F/16V		
Resistors				
VR815 or VR816 or	18E05510S04 18E05511S04 18E05510S04 18E05511S04	Semi-fixed 20kB Semi-fixed 20kB Semi-fixed 20kB Semi-fixed 20kB		
Meter P. C. Board				
LED's				
LD815	48E05514S01	Red		
LD816	48E05514S01	Red		
LD817	48E05514S01	Red		
LD818	48E05514S01	Red		
LD819	48E05513S01	Orange		
LD820	48E05513S01	Orange		
LD821	48E05513S01	Orange		
LD822	48E05513S01	Orange		
LD823	48E05513S01	Orange		
LD824	48E05513S01	Orange		
LD825	48E05513S01	Orange		
LD826	48E05513S01	Orange		
Timer Play P. C. Board				
Switch				
S802	40E05515S01	Rotary Switch (Timer mode)		
Motor A P. C. Board				
IC/Transistors				
IC901 or Q840 or Q841 or	51E06301S01 51E05060S01 48E05542S01 48E04784S01 48E05542S01 48E04784S01	MC14011BCP NJU4011BD 2SC945 KTC1815 2SC945 KTC1815		
Motor B P. C. Board				
Transistors				
Q845 or Q846 or	48E05542S01 48E04784S01 48E05542S01 48E04784S01	2SC945 (P) KTC1815 (GR) 2SC945 (P) KTC1815 (GR)		
Diode				
D845	48E04616S01	Silicon, 1N4148		
Q901 or Q903 or Q904 or Q905 or	48E05542S01 48E04784S01 48E05542S01 48E04784S01 48T65363F02 48E04785S01 48E05542S01 48E04784S01	2SC945 KTC1815 2SC945 KTC1815 2SA608 KTA1015 2SC945 KTC1815		
Diodes				
D840 D901 or D902 D903	48E04616S01 48T52739F15 48T40732F08 48E04616S01 48E04616S01	Silicon, 1N4148 Zener, HZ3 Zener, RD3.6E Silicon, 1N4148 Silicon, 1N4148		
D904 D905 D906 or D907	48E04616S01 48E04616S01 48T52739F15 48T40732F08 48E04616S01	Silicon, 1N4148 Silicon, 1N4148 Zener, HZ3 Zener, RD3.6E Silicon, 1N4148		
D908 D909	48E04616S01 48E04616S01	Silicon, 1N4148 Silicon, 1N4148		
Capacitors				
C902 C903	23E04635S07 23E04754S01	ELY., 4.7 μ F/50V ELY., 10 μ F/16V		
Resistors				
VR840 VR841	18E05522S01 18E05522S01	Semi-fixed 2kB Semi-fixed 2kB		

Symbol No.	Part No.	Description		
Resistors				
VR845	18E05522S01	Semi-fixed 2kB		
VR846	18E05522S01	Semi-fixed 2kB		
Dolby P. C. Board				
IC				
IC861	51E05539S01	CX20187		
Coils				
L861	24E05523S01	22mH		
L862	24E05523S01	22mH		
Capacitors				
C861	23E04754S08	ELY., 33 μ F/16V		
C862	23E04754S01	ELY., 10 μ F/16V		
C863	08E04735S04	MYL., 1000pF		
C864	08E04735S04	MYL., 1000pF		
C865	08E04735S16	MYL., 4700pF		
C866	08E04735S16	MYL., 4700pF		
C867	23E04635S04	ELY., 0.47 μ F/50V		
C868	23E04635S04	ELY., 0.47 μ F/50V		
C869	08E05500S01	MYL., 0.15 μ F		
C870	08E05500S01	MYL., 0.15 μ F		
C871	08E04735S06	MYL., 0.015 μ F		
C872	08E04735S06	MYL., 0.015 μ F		
C873	08E05500S02	MYL., 0.22 μ F		
C874	08E05500S02	MYL., 0.22 μ F		
C875	08E05500S03	MYL., 0.068 μ F		
C876	08E05500S03	MYL., 0.068 μ F		
C879	08E05500S05	MYL., 0.047 μ F		
C880	08E05500S05	MYL., 0.047 μ F		
C881	08E04735S12	MYL., 6800pF		
C882	08E04735S12	MYL., 6800pF		
C883	08E04735S05	MYL., 0.01 μ F		
C884	08E04735S05	MYL., 0.01 μ F		
C885	23E04635S09	ELY., 0.33 μ F/50V		
C886	23E04635S09	ELY., 0.33 μ F/50V		
C887	08E04735S09	MYL., 0.022 μ F		
C888	08E04735S09	MYL., 0.022 μ F		
C889	23E04754S02	ELY., 220 μ F/16V		

Symbol No.	Part No.	Description		
Dolby SW P. C. Board				
Diode				
D855	48E04616S01	Silicon, 1N4148		
Switches				
S855	40E05516S01	Push		
S856	40E05516S01	Push		
S857	40E05516S01	Push		
S858	40E05516S01	Push		
S859	40E05516S01	Push		
Resistors				
R855	06E05544S01	Carbon, 470 ohm 1/4W		
R856	06E05544S01	Carbon, 470 ohm 1/4W		
Control P. C. Board				
LED's				
LD860	48E05514S01	Red		
LD861	48E05514S01	Red		
Switches				
S860	40E05517S01	Key		
S861	40E05517S01	Key		
S862	40E05517S01	Key		
S863	40E05517S01	Key		
S864	40E05517S01	Key		
S865	40E05517S01	Key		
S866	40E05517S01	Key		
S867	40E05517S01	Key		
Headphone P. C. Board				
IC				
IC801	51E05540S01	NJM4556S		

Symbol No.	Part No.	Description				Symbol No.	Part No.	Description			
Transistors						S701	40E05434S01	Switch, Leaf, PLAY for Mechanism A			
Q801	48E05541S01	2SD1012				S702	40E05435S01	Switch, Leaf, FF/REWIND for Mechanism A			
Q802	48E05541S01	2SD1012				S703	40E05433S01	Switch, Leaf, Tape Detect for Mechanism A			
Q803	48T65363F02	2SA608				S704	40E05433S01	Switch, Leaf, CrO2 Select for Mechanism A			
or	48E04785S01	KTA1015				S705	40E05434S01	Switch, Leaf, PLAY for Mechanism B			
Jack						S706	40E05433S01	Switch, Leaf, Tape Detect for Mechanism B			
JK801	09E05518S01	6.3				S707	40E05433S01	Switch, Leaf, FWD REC Safety for Mechanism B			
Switch						S708	40E05433S01	Switch, Leaf, Metal Select for Mechanism B			
S801	40E05519S01	Rotary, Reverse Mode				S709	40E05435S01	Switch, Leaf, FF/REWIND for Mechanism B			
Capacitors						S710	40E05433S01	Switch, Leaf, CrO2 Select for Mechanism B			
C801	23E04754S03	ELY., 100 μ F/16V				S711	40E05433S01	Switch, Leaf, REV REC Safety for Mechanism B			
C802	23E04754S03	ELY., 100 μ F/16V				SD701	01E05399S01	Solenoid 1 for Mechanism A			
C803	23E04635S08	ELY., 2.2 μ F/50V				SD702	01E05399S01	Solenoid 2 for Mechanism A			
C804	23E04635S08	ELY., 2.2 μ F/50V				SD703	01E05399S01	Solenoid 1 for Mechanism B			
C805	21E04638S03	CER., 100pF				SD704	01E05399S01	Solenoid 2 for Mechanism B			
C806	21E04638S03	CER., 100pF				● T801	25E05475S01	TRANS., Power EI57 120/220/240V			
C807	23E04635S03	ELY., 1 μ F/50V				○ T801	25E05475S02	TRANS., Power, EI57 120V			
C808	23E04635S03	ELY., 1 μ F/50V				△ T801	25E05475S02	TRANS., Power, EI57 120V			
C809	23E04754S05	ELY., 47 μ F/16V				● S800	40E05495S01	Switch, Voltage Selector			
Resistors											
VR801	18E05520S01	Rotary, 50k Ω									
VR802	18E05521S01	Rotary, 50k Ω with Switch									
Miscellaneous											
HD701	88E05362S01	Head, Deck A									
HD702	88E05440S01	Head, Deck B									
IC701	51E05436S01	Hall IC LB9050TN for Mechanism A									
IC702	51E05436S01	Hall IC LB9050TN for Mechanism B									
M701	59E05385S01	Motor A									
M702	59E05385S01	Motor B									
● P801	28E04687S01	Cord, AC									
○ P801	28E04686S01	Cord, AC									
△ P801	28E04686S01	Cord, AC									

Note : ● : For multivoltage model (AD), ○ : For USA model (UC),
 △ : For Canadian model (UQ), Others : Common.

Parts List by the Destination

Symbol No.	Description	POWER SOURCE		
		AD ● 220V	UQ △ 120V	UC ○ 120V
R224	Resistor	06E05508S01	06E06053S01	06E06053S01
T801	Transformer	25E05475S01	25E05475S02	25E05475S02
P801	AC Cord	28E04687S01	28E04686S01	28E04686S01
SW800	Voltage Selector	40E05495S01	Not Used	Not Used
55	Back Panel	15E05470S01	15E05470S02	15E05470S02
106	Owner's Manual	68P96552F45	68P96552F45	68P96552F44

Cabinet Assembly Parts List

Symbol No.	Index	Part No.	Description	Symbol No.	Index	Part No.	Description
2	2-B	01E05444S01	Assy., Panel, Front	53		75E04678S01	Foot, Back
7		03E04701S01	Screw, Taptite, 3 × 8	54		03E04702S06	Screw, Taptite, 4 × 10
8	3-C	64E05445S01	Mirror, Cassette	● 55	2-G	15E05470S01	Panel, Back
9	3-B	01E05446S01	Assy., Door, Left	○ 55	2-G	15E05470S02	Panel, Back
11	4-A	64E05447S01	Window, Door, Left	△ 55	2-G	15E05470S02	Panel, Back
12		41E05448S01	Spring, Leaf	56		43E04688S01	Bushing, Cord
13		03E05066S02	Screw, Taptite, 2 × 5	57	5-F	03E04702S07	Screw, Taptite, 3 × 10
14	4-C	01E05449S01	Assy., Door, Right	58	3-F	02E05471S01	Nut, Flange
16	4-B	64E05450S01	Window, Door, Right	60	4-G	75E05472S01	Cushion
17	3-C	07E05451S01	Cover	62	4-F	84E05473S01	PCB31
18		03E04701S03	Screw, Taptite, 2.6 × 8	63	3-F	22E05474S01	Terminal, Pin
19	3-D	41E05452S01	Spring, Torsion, Deck-B	65		14E06054S01	Sheet, Insulation
20	2-D	41E05453S01	Spring, Torsion, Deck-A	67	2-D	81E05477S01	Assy., Tape Mechanism A
21	2-D	04E05454S01	Washer, 2.6	68	1-E	15E05405S01	Holder
22	3-D	07E05455S01	Holder, Door	70	2-E	81E05478S01	Assy., Tape Mechanism B
23	3-D	64E05456S01	Plate, Indication	71	2-D	07E05479S01	Holder, Base-L
25	4-D	36E05457S01	Knob, REC	72	2-E	07E05480S01	Holder, Base-R
26	4-D	41E05458S01	Spring, Coil	73		41E05481S01	Spring, Coil
27	4-E	36E05459S01	Assy., Knob, Mechanism	74	1-D	07E05482S01	Lever, Door Lock-L
31	4-E	36E05460S01	Knob 95	75	2-F	07E05483S01	Lever, Door Lock-R
32	3-E	03E05066S03	Screw, Taptite, 2 × 8	76	2-D	07E05484S01	Lever, Eject-L
33		36E05461S01	Knob, TIMER/ LEVEL/REVERSE	77	3-F	07E05485S01	Lever, Eject-R
34	3-E	36E04672S01	Knob, DOLBY/SPEED	78		07E05486S01	Slider
36		03E04775S02	Screw, 3 × 6	79		46E05487S01	Stud
38	3-A	36E04673S01	Knob, POWER	80		43E05488S01	Spacer
39	5-B	64E05462S01	Plate, Door, Deck-B	81		43E05489S01	Spacer
40	4-A	64E05463S01	Plate, Door, Deck-A	82		03E05490S01	Screw, 2 × 4
41		01E05464S01	Assy., Damper	83		03E05490S02	Screw, 2 × 10
43	2-D	72E05466S01	Counter	84		03E05490S03	Screw, 2 × 12
44		04E05467S01	Washer, 2.6	85	2-E	42E05491S01	Belt
45	3-E	03E05066S04	Screw, Taptite, 2.6 × 6	86	2-C	41E05492S01	Spring, Torsion, L
46	3-E	36E05468S01	Knob, EJECT	87	3-F	41E05493S01	Spring, Tortion, R
48		03E04701S04	Screw, Taptite, 3 × 10	88		04E05494S01	E-ring
49	1-F	15E05469S01	Assy., Cabinet, Top	89	3-G	05E04709S01	Rivet, Nylon
52		75E04521S01	Foot, Front	92	3-D	05E04709S02	Rivet, Nylon
				95	3-G	29E04693S01	Lug
				96		03E05066S05	Screw, Taptite, 2.6 × 10
				97	3-G	04E06190S01	Washer, Toothed
				98		03E04702S08	Screw, Taptite, 3 × 6
				99	4-B	04E06474S01	Washer, 2.0

Notes: The parts not indicated in this list are not supplied.

● : For multivoltage model (AD), ○ : For USA model (UC),

△ : For Canadian model (UQ), Others : Commo

Exploded View (Cabinet)

1

2

3

4

5

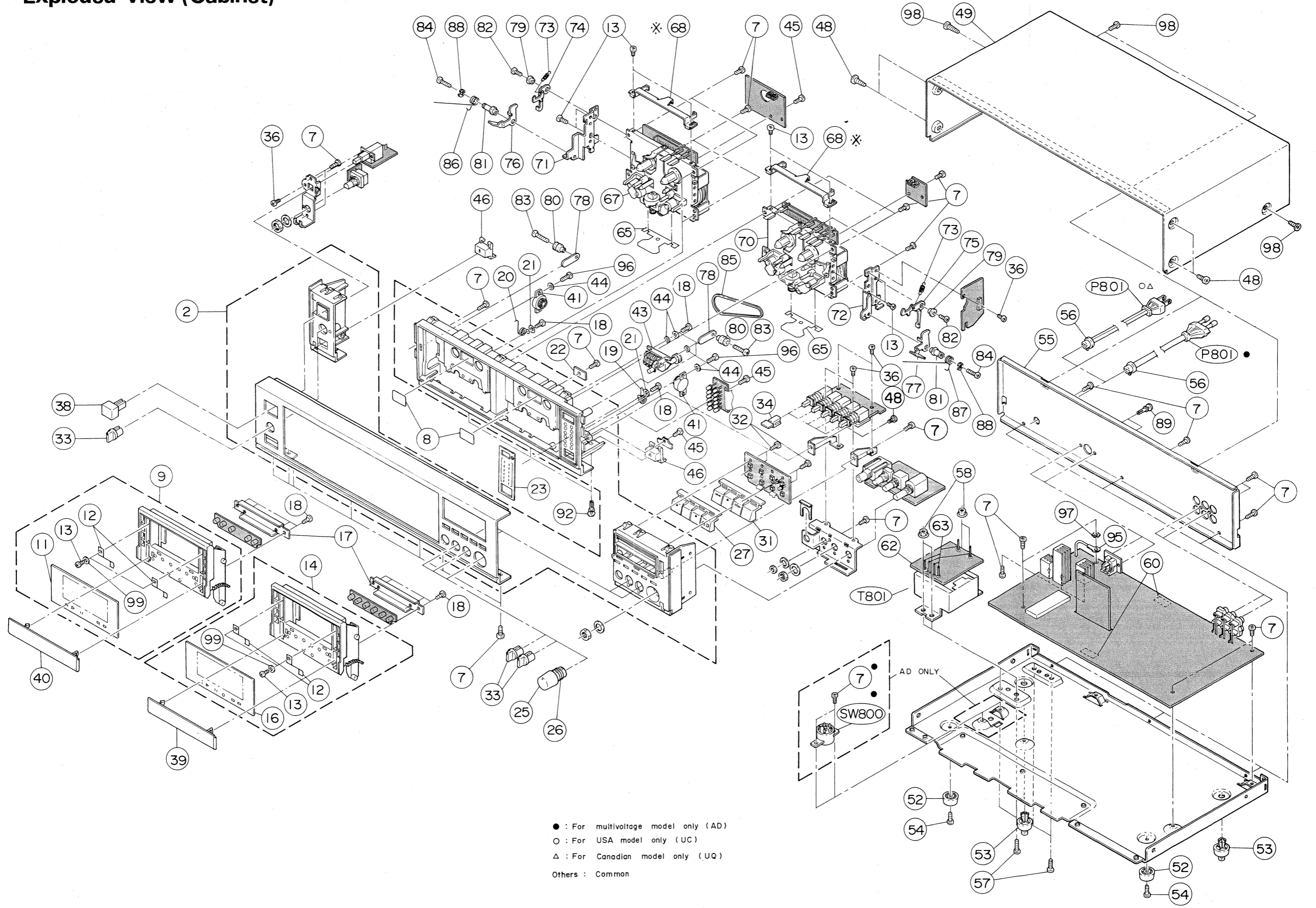

● : For multivoltage model only (AD)
 ○ : For USA model only (UC)
 △ : For Canadian model only (UQ)
 Others : Common

A

B-34-

C

D

E

F-35-

G

H

Exploded View (Cassette Deck)

1

2

3

4

5

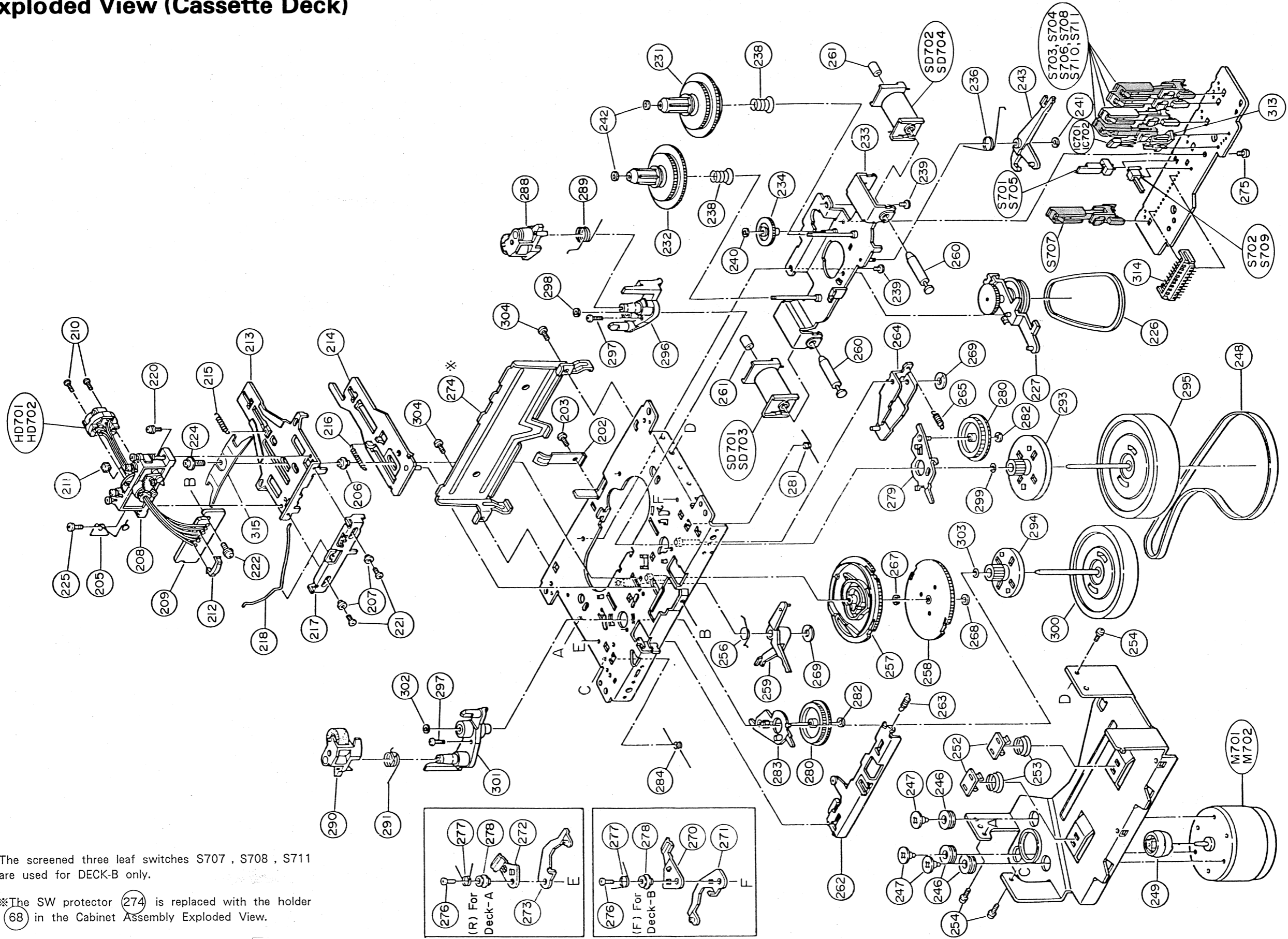

The screened three leaf switches S707, S708, S711 are used for DECK-B only.

※The SW protector (274) is replaced with the holder (68) in the Cabinet Assembly Exploded View.

Cassette Deck Assembly Parts List

Note : The parts not indicated in this list are not supplied.

Symbol No.	Index	Part No.	Description	Symbol No.	Index	Part No.	Description
202	3-D	41E05346S01	Spring, Pack	253	4-F	41E05387S01	Spring, Damper
203	3-D	03E05347S01	Screw, Tapping, Special, 2 × 3	254		03E05388S01	Screw, Tams, 2 × 4
205	3-A	41E05348S01	Spring, Clamp	256	4-E	41E05389S01	Spring, Arm, M Trigger
206	3-C	43E05349S01	Collar, Panel	257	4-E	44E05390S01	M Gear
207	4-C	43E05350S01	Collar, CHP Lever	258	4-F	44E05391S01	Cam Gear, RF
208	3-B	01E05351S01	Assy., Head Base	259	4-E	45E05392S01	Arm, M Trigger
* 209	4-B	84E05352S01	Relay Board for Deck A	260		47E05393S01	Plunger
* 209	4-B	84E05439S01	Relay Board for Deck B	261		43E05394S01	Holder, Plunger
210	2-A	03E05353S01	Screw, Head Collar	262	5-E	01E05395S01	Assy., Lever, CH Slide
211	3-A	43E05354S01	Spacer	263	4-F	41E05396S01	Spring, Lever, CH Slide
212	4-B	43E05355S01	Clamp, Wire	264	2-F	01E05397S01	Assy., Lever, P Kick
213	2-B	15E05356S01	Head Panel (A)	265	3-F	41E05398S01	Spring, PK Lever
214	2-C	15E05357S01	Assy., Head Panel (B)	267	3-F	04E05400S01	E Ring, 2.0
215	2-B	41E05358S01	Spring, RC	268	4-F	04E05401S01	Washer, 1.55
216	3-C	41E05359S01	Spring, Panel	269		04E05402S01	Washer, 2.1
217	4-C	45E05360S01	Lever, CHP	* 270	5-D	07E05441S01	E Stopper A (F), Deck B
218	4-B	41E05361S01	Spring, Pinch Roller	* 271	5-E	07E05442S01	E Stopper B (F), Deck B
220	2-B	03E05363S01	Screw, Semus, 2 × 5	* 272	5-D	07E05403S01	E Stopper A (R), Deck A
221	4-C	03E05364S01	Screw, Camera, 1.7 × 3	* 273	5-D	07E05404S01	E Stopper B (R), Deck A
222	3-B	03E05365S01	Screw, Tapping, 2 × 5	* 274	3-C	15E05405S01	SW Protector
224	3-B	03E05366S01	Screw, Tapping, 2 × 5	275	2-G	03E05406S01	Screw, Tapping, 2 × 5
225	3-A	03E05367S01	Screw, Bind, 2 × 5	276	5-C	03E05407S01	Screw, Tapping, 2 × 6
226	2-G	42E05368S01	Belt, RF	277		41E05408S01	Spring, E Stopper, (F)
227	3-F	01E05369S01	Assy., RF Clutch	278	5-C	43E05409S01	Collar, E Stopper
231	1-D	01E05370S01	Assy., T Reel (F)	279	3-F	01E05410S01	Assy., Arm, T Gear (F)
232	2-D	01E05371S01	Assy., T Reel (R)	280		44E05411S01	T Gear
233	1-E	01E05372S01	Assy., Reel Base	281	3-E	41E05412S01	Spring, TG Arm, (F)
234	2-E	44E05373S01	Gear, FF	282		04E05413S01	Washer, 1.2
236	1-F	41E05374S01	Spring, Arm, FR Trigger	283	4-E	01E05414S01	Assy., Arm, T Gear (R)
238		41E05375S01	Spring, B.T. (R)	284	4-D	41E05415S01	Spring, TG Arm, (R)
239	2-F	03E05376S01	Screw, Tapping, 2 × 4	288	2-D	01E05416S01	Assy., Arm, Pinch Roller, (F)
240	2-E	04E05377S01	Washer, 1.2	289	2-D	41E05417S01	Spring, P Arm, (F)
241	1-F	04E05378S01	Washer, 2.1	290	5-C	01E05418S01	Assy., Arm, Pinch Roller, (R)
242	1-D	04E05379S01	Washer, 1.4	291	5-C	41E05419S01	Spring, P Arm, (R)
243	1-F	45E05380S01	Arm, RF Trigger	293	3-F	44E05420S01	FL Gear, (F)
246	5-F	75E05381S01	Rubber, Motor				
247	5-F	03E05382S01	Screw, Motor Collar				
248	2-G	42E05383S01	Belt, Main				
249	5-G	49E05384S01	Pulley, Motor				
252	4-F	07E05386S01	Plate, FL Patch				

Notes : All parts are common for Deck A and Deck B except those marked by * .

* The SW protector 274 is replaced with the holder 68 in the Cabinet Assembly Parts List when the mechanism is assembled to the cabinet.

Note: The parts not indicated in this list are not supplied.

Symbol No.	Index	Part No.	Description			Symbol No.	Index	Part No.	Description		
294	3-F	44E05421S01	FL Gear, (R)								
295	3-G	49E05422S01	Assy., Flywheel, (F)								
296	2-D	01E05423S01	Assy., FL Metal, (F)								
297		03E05424S01	Screw, Tapping, (M2 × 6)								
298	2-D	04E05425S01	Washer, Nylon, 2.1								
299	3-F	04E05426S01	Washer, HL, 2.3								
300	4-F	49E05427S01	Assy., Flywheel, (R)								
301	4-C	01E05428S01	Assy., FL Metal, (R)								
302	4-C	04E05429S01	Washer, Nylon, 1.8								
303	3-F	04E05430S01	Washer, HL, 2.1								
304		03E05431S01	Screw, Tapping, (M2 × 4)								
313	1-G	48E05437S01	IC Protector								
* 314	2-G	09E05438S01	Connector for Deck A								
* 314	2-G	09E05443S01	Connector for Deck B								
315	3-B	64E05752S01	Plate, Spring								

Notes: All parts are common for Deck A and Deck B except those marked by *.

Packing Assembly Parts List

Symbol No.	Part No.	Description			Symbol No.	Part No.	Description		
101	56E05496S01	Carton, Packing							
102	56E05497S01	Box, Snow							
103	56E05498S01	Bag, Polyester							
104	56E04782S01	Bag, Polyester							
105	56E05499S01	Bag, Polyester							
○ 106	68P96552F44	Owner's Manual							
● 106	68P96552F45	Owner's Manual							
△ 106	68P96552F45	Owner's Manual							
107	28E04778S02	Cord, Partch							

Notes : The parts not indicated in this list are not supplied.
 ● : For multivoltage model (AD), ○ : For USA model (UC),
 △ : For Canadian model (UQ), Others : Common.

Packing Method View

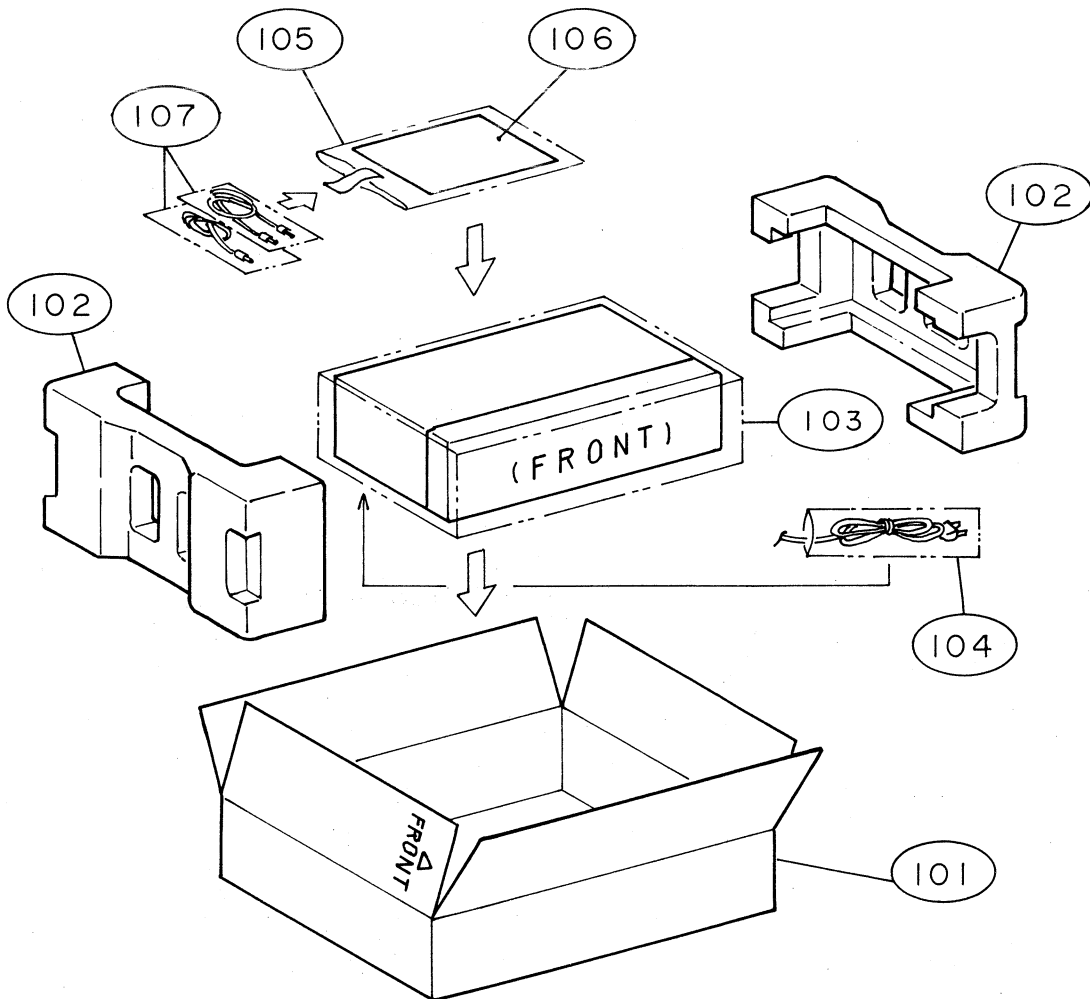

Semi-Conductor Lead Identifications

μ PC1330HA : IC101

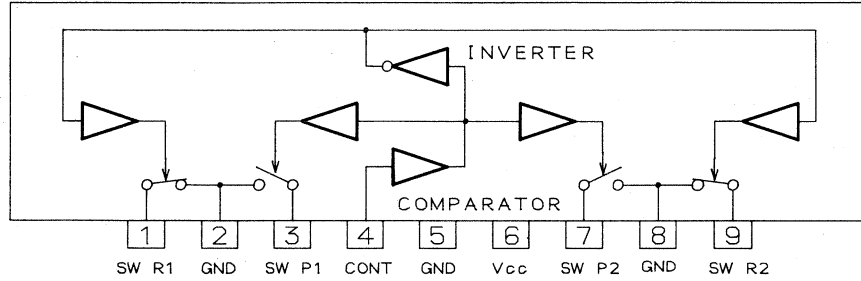
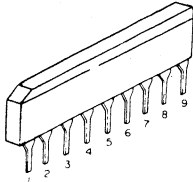

NJM2068 : IC102, 401

NJM4558S : IC104

NJM4556S : IC801

TA75558S : IC203

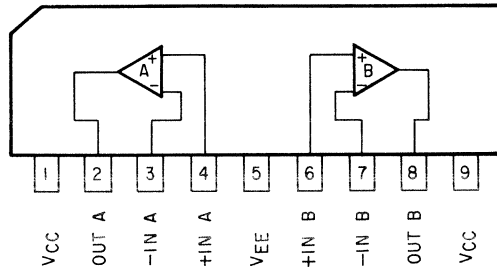
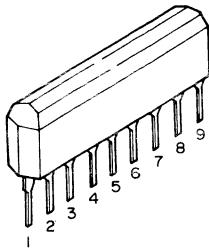

CX20188 : IC103

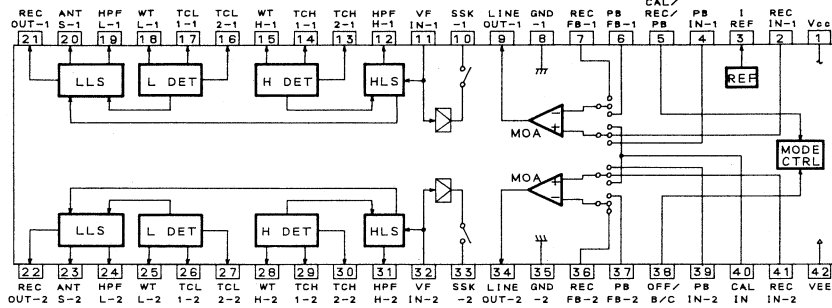
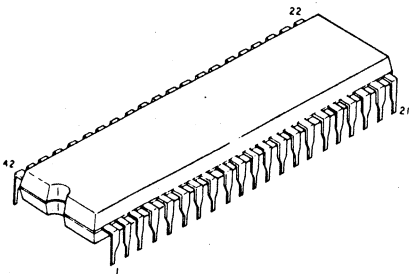

NJU4066B : IC201, 204, 205, 402,
IC403, 404

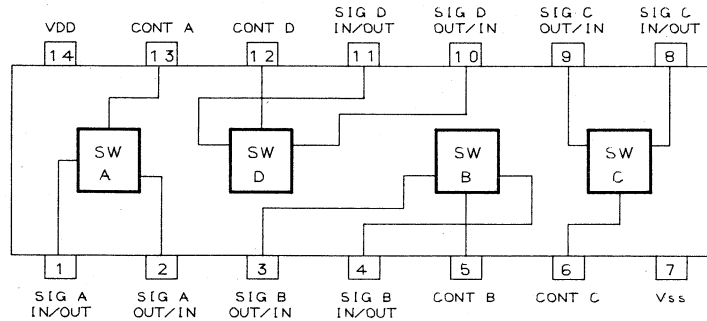
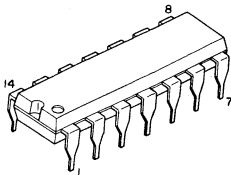

μ PC1297CA : IC202

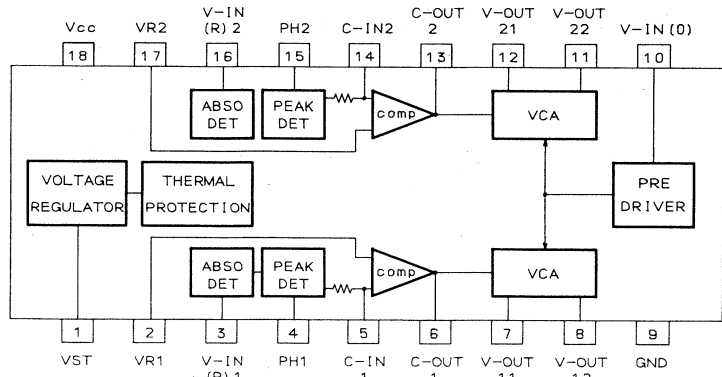
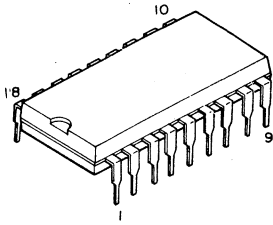

TCV1008 : IC501

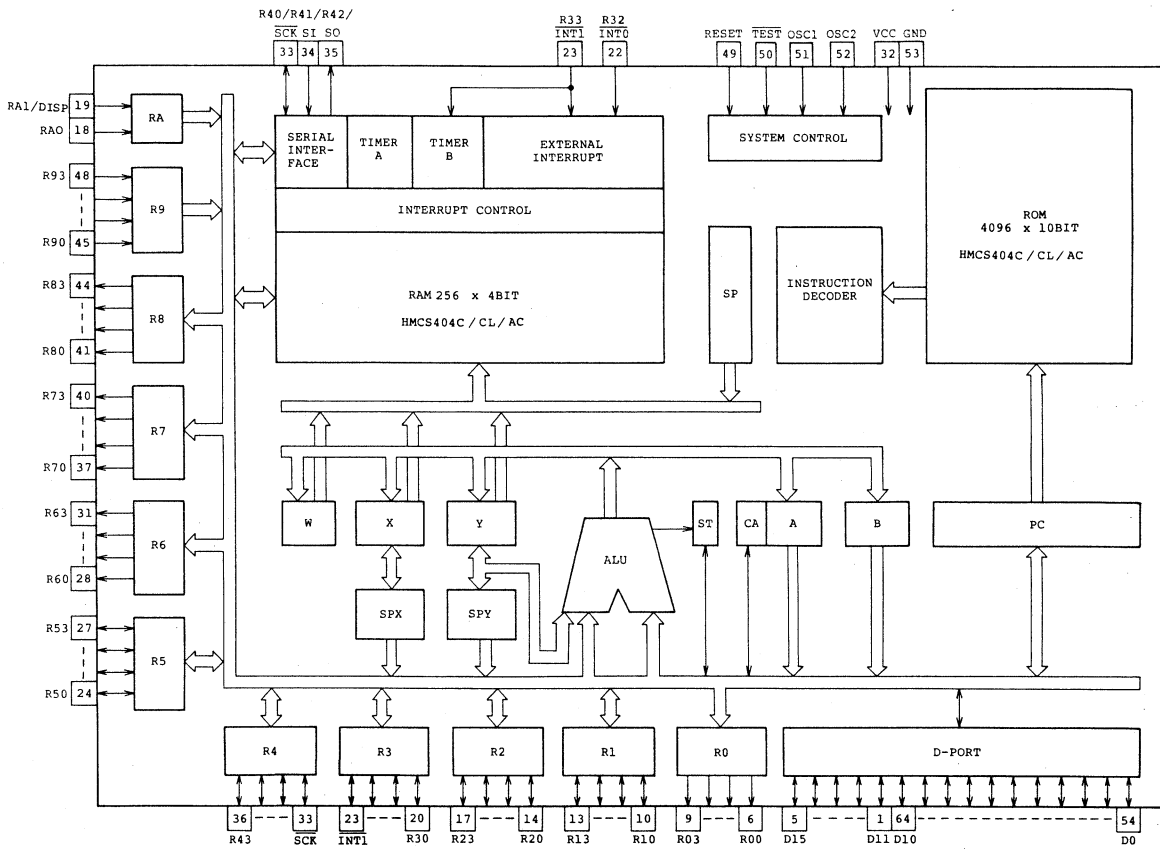
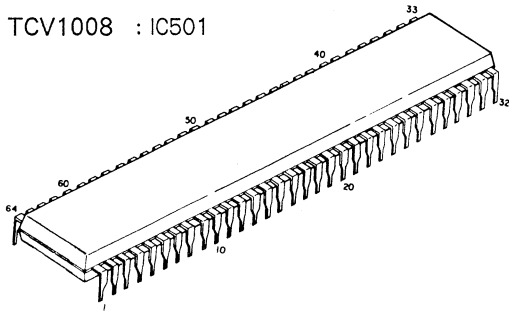

PST523E : IC502

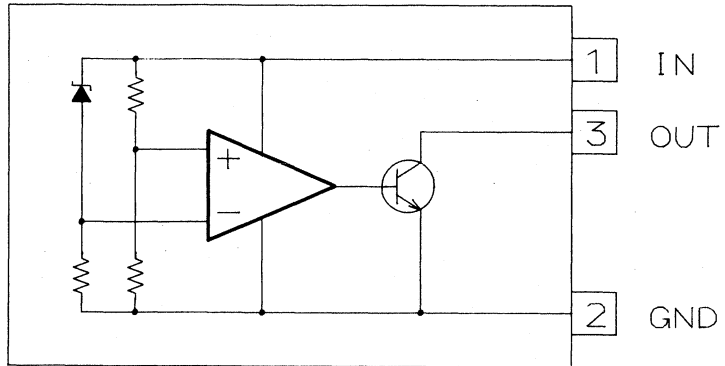
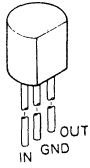

MC7812CT : IC602
MC78M12CT : IC601
MC78M06CT : IC603

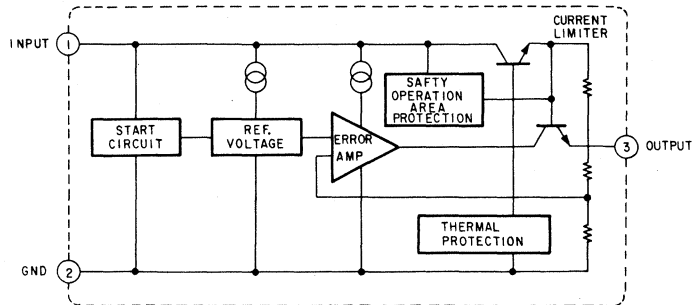
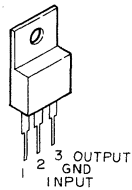

TA7666P : IC815

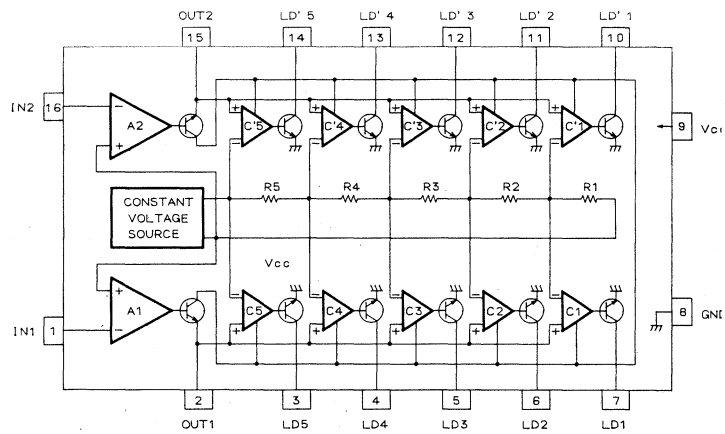
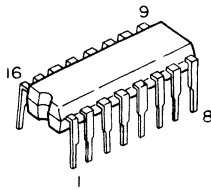

CX20187 : IC861

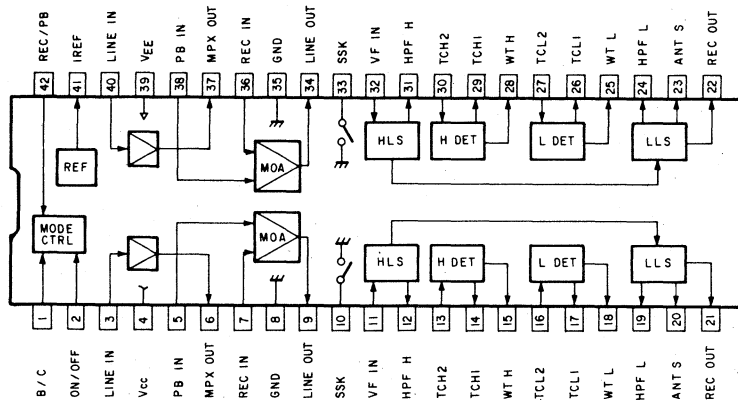
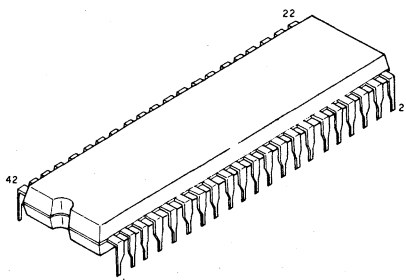

MC14011BCP : IC901

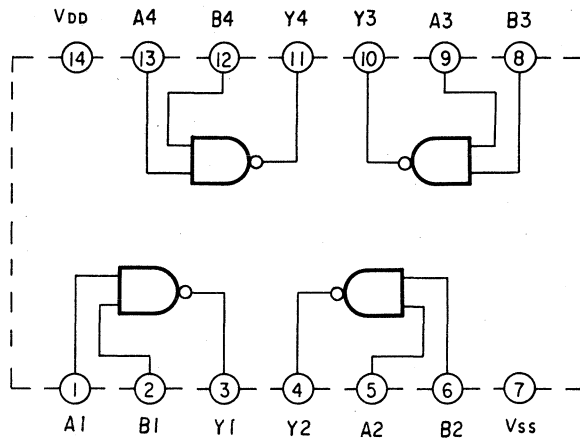
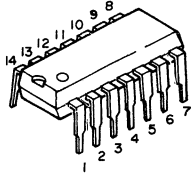

2SC945 : Q104, 105, 107~112
 or KTC1815 Q202~209, 212
 Q217~227, 401~403
 Q408, 409, 504~506
 Q508, 509, 512~515
 Q517~521
 Q815, 816, 840, 841
 Q845, 846



2SD1012 : Q101, 102, 109, 110, 214, 215
 Q405, 406, 503, 507
 Q801, 802
 2SB808 : Q501, 502, 510, 511



2SA608 : Q103, 201, 211, 213
 or KTA1015 Q216, 228, 407, 516
 Q522, 803



2SD438 : Q210

